

Remove the protective film from the rails.

**From the outside only**, apply sealant to the bottom of the enclosure and 50mm up the wall channels, angled profile and vertical joints as shown.

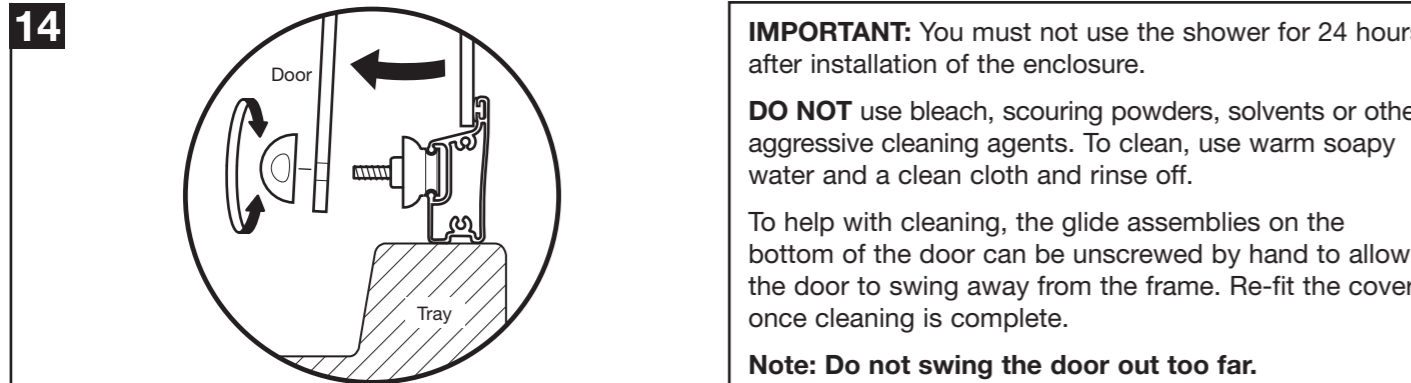

**IMPORTANT:** You must not use the shower for 24 hours after installation of the enclosure.

**DO NOT** use bleach, scouring powders, solvents or other aggressive cleaning agents. To clean, use warm soapy water and a clean cloth and rinse off.

To help with cleaning, the glide assemblies on the bottom of the door can be unscrewed by hand to allow the door to swing away from the frame. Re-fit the cover once cleaning is complete.

**Note:** Do not swing the door out too far.

## 1200 x 950 CRESCENT SHOWER ENCLOSURE

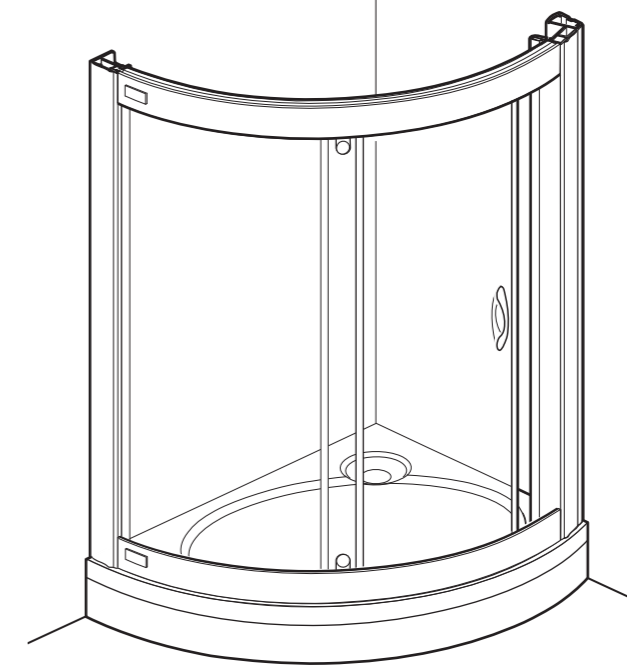

**Please read these instructions carefully and keep for future reference. Incorrect fitting will invalidate the guarantee.**

### SAFETY

- Handle glass with great care. Although the glass is very tough, sharp impacts can damage both the glass and metal frame.
- Make sure there are no hidden pipes or cables hidden in the wall where you intend to drill.
- Wear safety goggles, shoes and appropriate clothing.
- If you have long hair, tie it back out of the way.

### BEFORE INSTALLATION

- Two people are needed to carry out parts of the procedure.
- Check that the shower tray is level in all directions. The enclosure will not sit correctly on an uneven surface. If uneven, the wall channels may not fit and the doors may not shut correctly.
- The enclosure should be fitted on tiled walls which are sealed with waterproof grout. There must be a good silicone seal between the rim of the shower tray and the wall.
- This product is designed to be fitted to a 1200 x 950 Crescent tray only.
- Always check very carefully that components are vertical.
- To avoid damage, use the opened out packaging to build the enclosure on.
- Areas requiring silicone sealant should be cleaned with methylated spirit first.

### Equipment needed:

Drill, 6.5mm Masonry Bit, 4.5mm & 3mm Metal Bits (general), M4 Allen Key, Crosshead Screwdriver, Large Flatblade Screwdriver, Spirit Level, Scissors, Pencil, Silicone Sealant, Tape Measure, Masking Tape, Methylated Spirit.

**Note:** The screws and wall plugs supplied are for masonry walls. For lightweight walls i.e. stud partition, plasterboard etc, use the correct type of fixings.

A PRODUCT OF THE CORAM GROUP OF COMPANIES



















Coram Showers Ltd. Stanmore Industrial Estate, Bridgnorth, Shropshire WV15 5HP, UK  
www.coram.co.uk

**CUSTOMER CARELINE +44 (0) 1746 713410**

Check contents of pack before installation.

If there is anything missing, contact our Customer Careline for assistance.

**CUSTOMER CARELINE: +44 (0) 1746 713410**

	PN3230	8		PN60058	1
	PN3225 32mm	16		PN50128 PN50129	1/1
	PN3222 10mm	12		PN50126 PN50127	1/1
	PN80137 PN50109	2/2		PN50121 PN50120	1/1
	PN60066 20mm	2		PN50226 PN50227	1/1
	PN60017 16mm	2		PN40042	2
	PN60063 PN50101	2/2		PN6022002	1
	PN50102 PN50103	4/4		PN60162	1
	PN80376 PN80375	2/2		PN60162	1

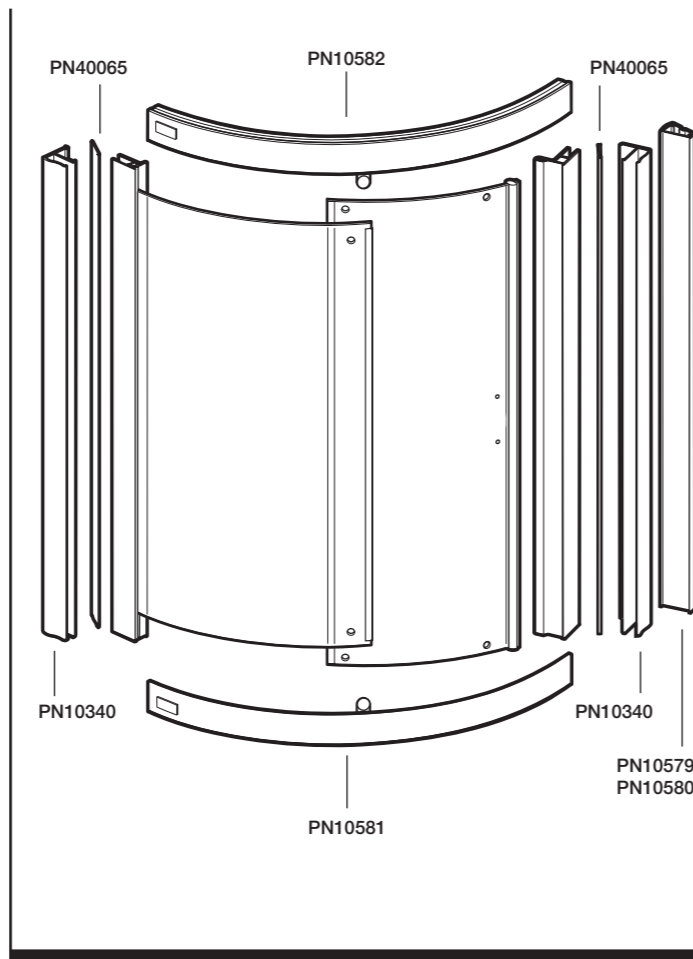

**10**

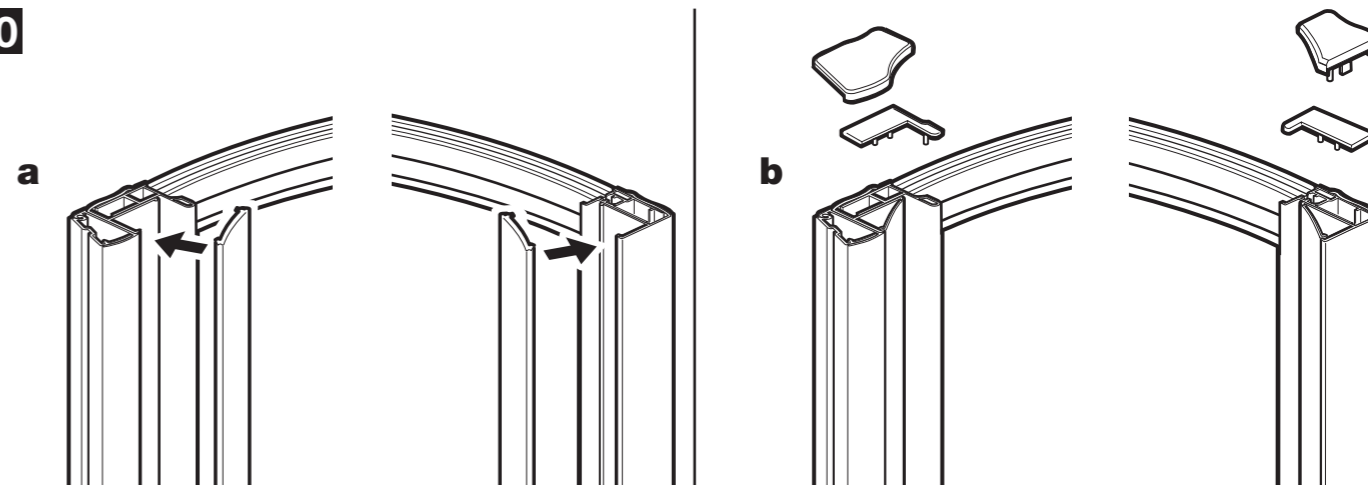

**a:** Push-fit the wall channel covers.

**b:** Select the appropriate top covers and push-fit into position.

**11**

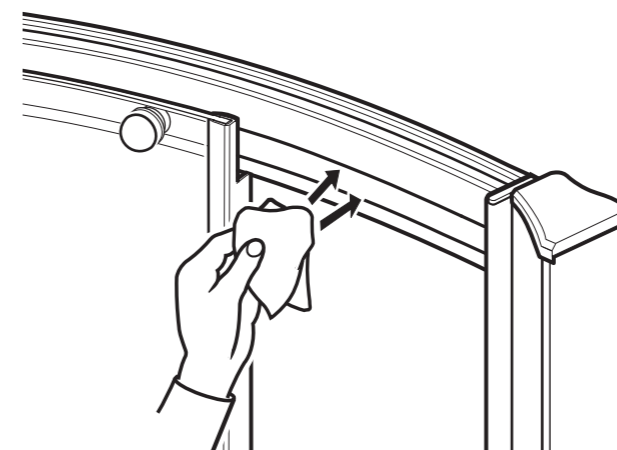

Lubricate the inner top and bottom rails using the wipe provided.

**1**

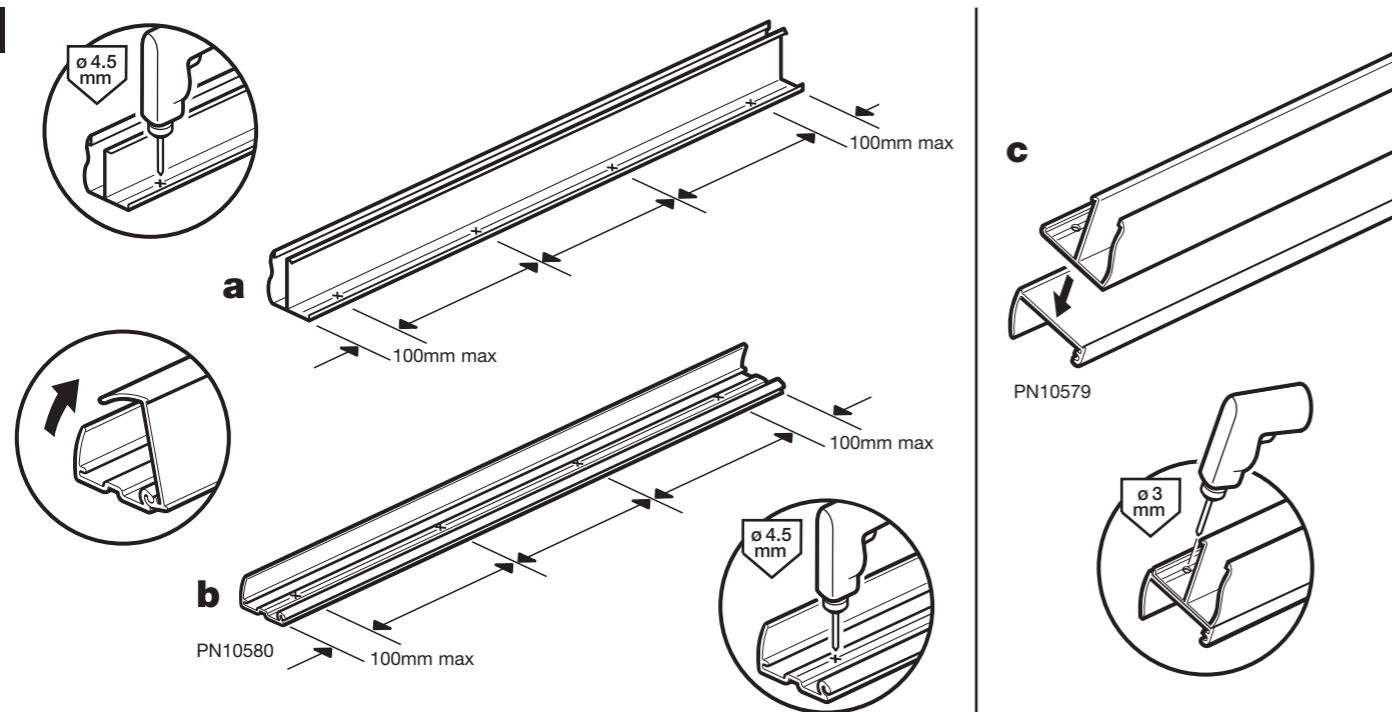

**a:** Drill holes in both wall channels using a 4.5mm drill bit, through the edge shown in between the grooves.

**b:** Separate the two sections of the angled profile. Drill holes in the back half where shown in between the grooves using a 4.5mm drill bit.

**c:** Place a wall channel on the top face of the other half of the angled profile, **note the orientation of the profile.**

Mark and drill through the holes in the wall channel into the profile using a **3mm drill bit.**

**IMPORTANT:** Ensure the wall channel you use as a template is the one that fixes to the profile in step 3.

**12**

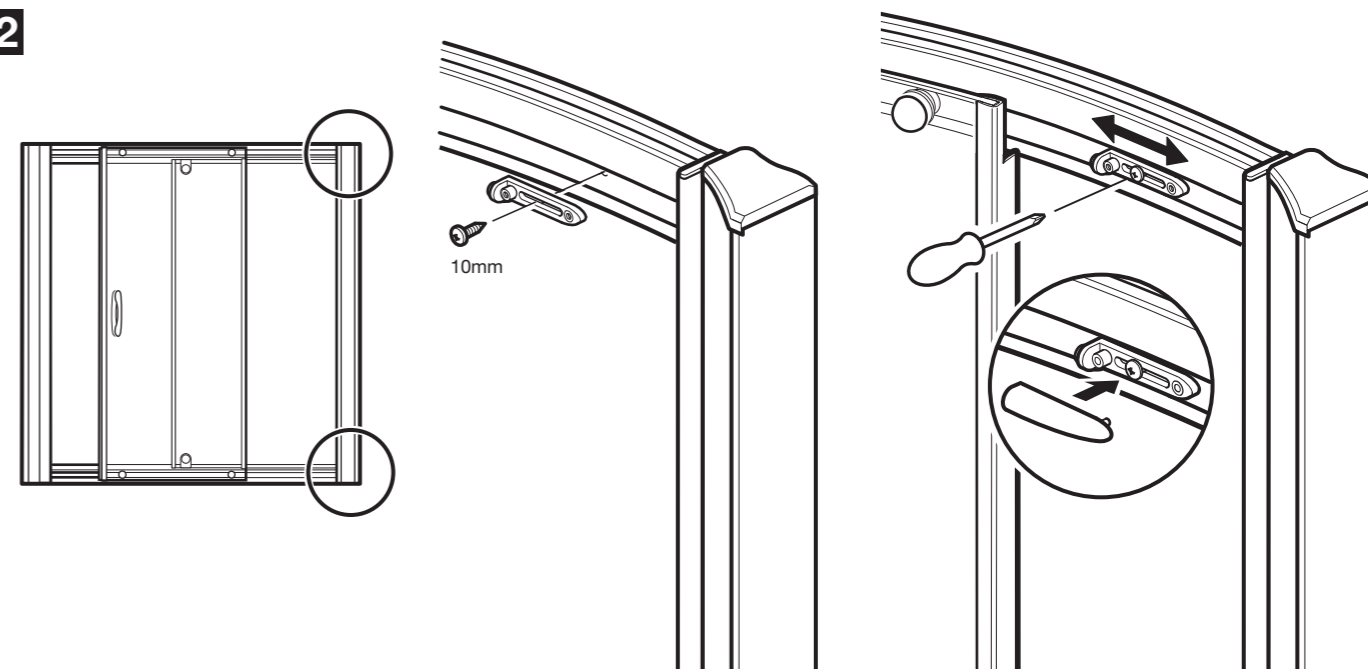

Fix the door stops to the fixed panel end of the top and bottom rails using 10mm screws.

Adjust the stops so they both hit the door seal at the same time. Push-fit the door stop covers.



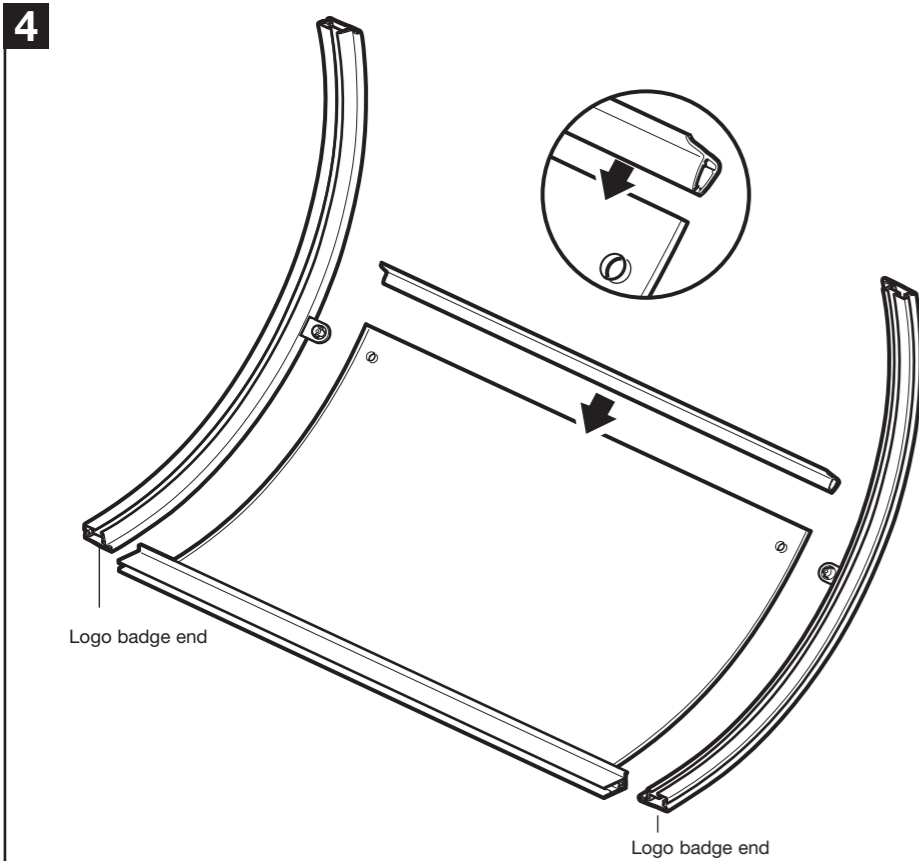

Trim the seal to the length of the glass and push-fit onto the edge of the fixed panel. The flap on the seal must be on the inside face of the panel.

Place the top and bottom rails against the fixed panel. The rails **must** be positioned with the 'logo badges' in the positions indicated and the factory fitted seal flush with the logo end of the rails.

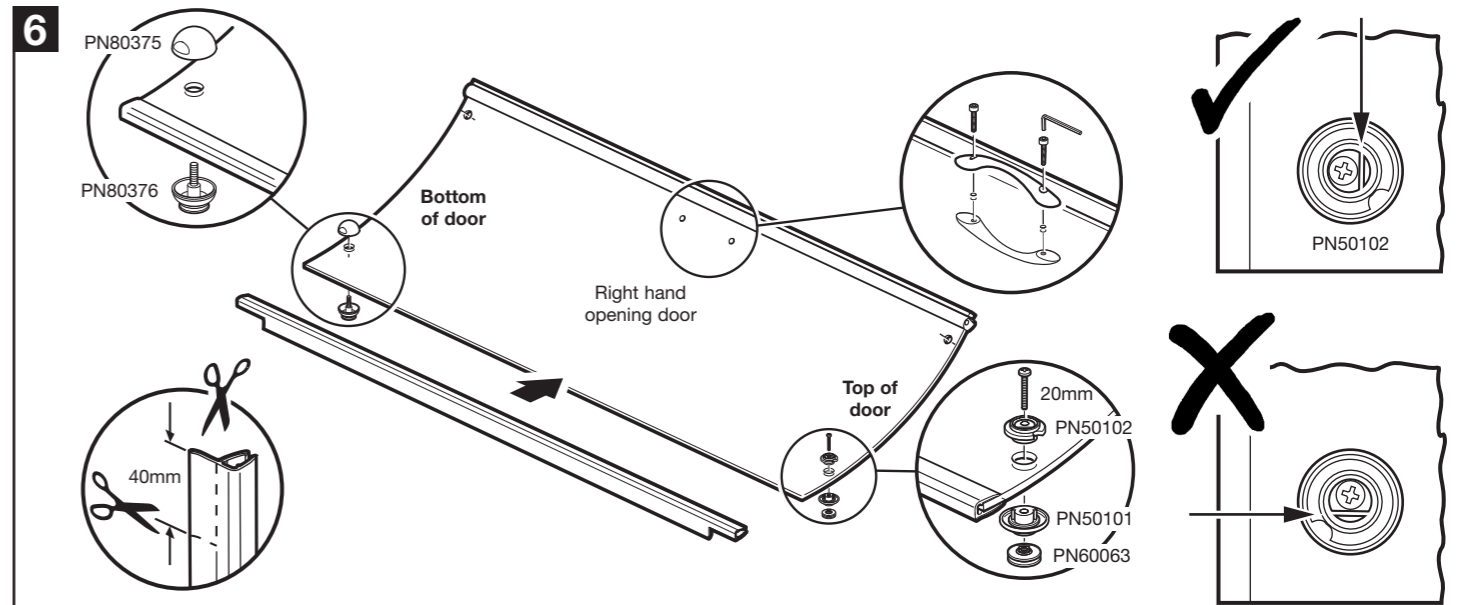

Trim the seal to the length of the glass. Cut 40mm off of the seal flap at the top and bottom and push-fit onto the edge of the door with the flap on the outside.

Fit the door handles with the allen bolts on the inside of the door. Tighten using the allen key but **do not over tighten**.

**Top of door:** Fit runner assemblies to the door using **20mm screws**. Ensure the square hole on the back of the door moulding (PN50101) fits over the square on the wheels. When assembled the slot in each part (PN50102) should be vertical as shown. **Do not over tighten**.

**Bottom of door:** Fit glide assemblies to the door as shown and tighten by hand.

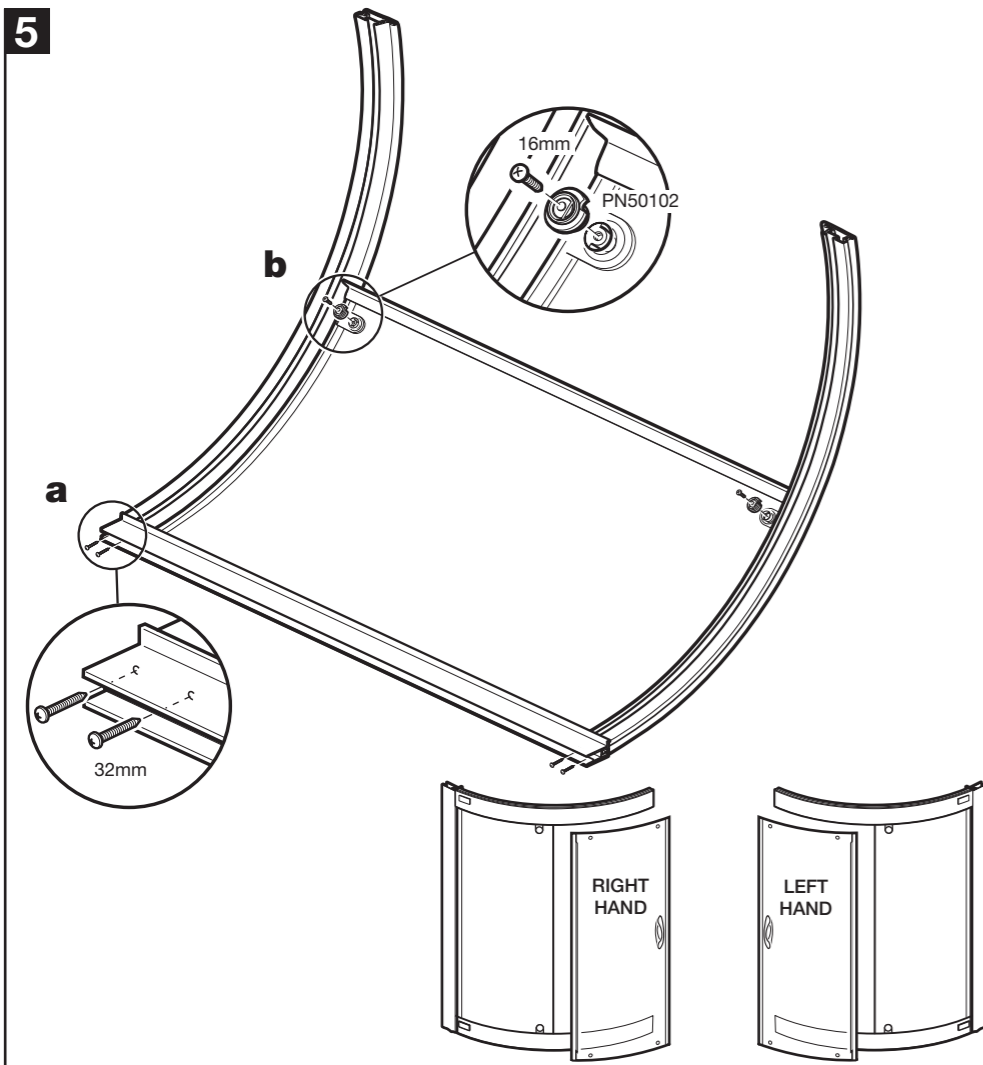

Position the top and bottom rails under and against the fixed panel. Align the brackets on the rails with the holes in the fixed panel ensuring the horizontal seals on the rails are not twisted.

**a:** Fix at the corners using 32mm screws, **do not over tighten**.

**b:** If necessary move the rail brackets so they line up with the holes in the glass. Place door runner mouldings (PN50102) onto the rail brackets and fix using **16mm screws, do not over tighten**.

Decide on the opening side of the enclosure, you will need to know which is the top and bottom of the door in the next step.

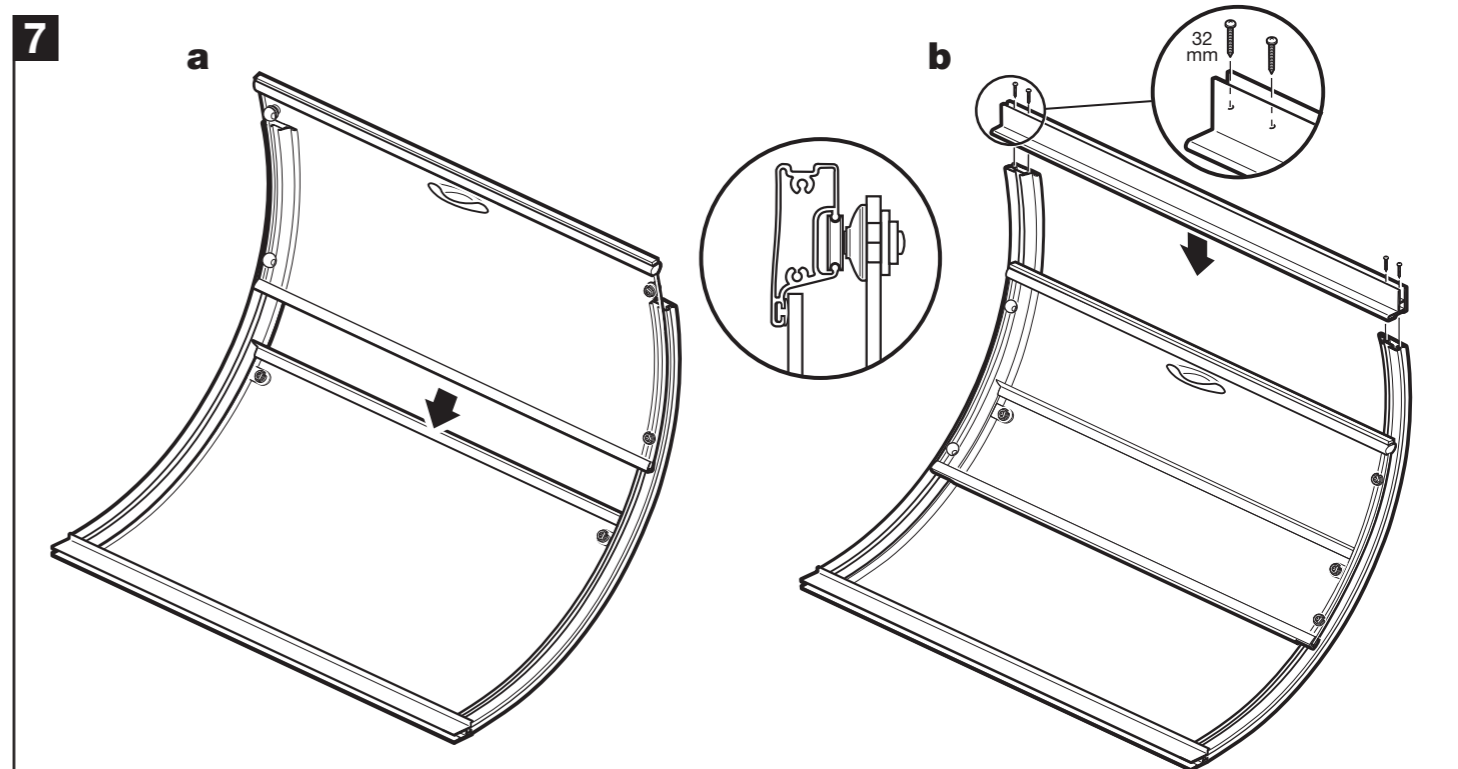

**a:** This stage must be done with two people to avoid damaging the runners and rails. Slide the door onto the rails, door seal end first. Make sure the runner wheels are correctly located in the rails as shown. The door will need to be pushed past the vertical seal on the fixed panel.

**b:** Fix the magnetic closing profile onto the top and bottom rails using 32mm screws.