

PILLAR SHOWER PANELS



Please read these instructions carefully and keep for future reference. Incorrect fitting will invalidate the guarantee.

SAFETY

- Handle glass with care. Sharp impacts can damage the metal components and could shatter the glass.
- Do not remove the plastic corner protectors from the glass panels until the panels are about to be fitted.
- As the parts are large, we recommend that two people are needed to carry out parts of the installation.
- Make sure there are no hidden pipes or cables in the floor and walls where you intend to drill.
- Wear safety goggles, shoes and appropriate clothing.

BEFORE INSTALLATION

- The enclosure will not sit correctly on an uneven surface. If uneven, the wall channels may not fit.
- **Note: If not fitted on a tray, ensure the enclosure is fitted to a tiled or waterproof composite floor.**
- The enclosure should be fitted on tiled walls which are sealed with waterproof grout.
- Always check very carefully that components are vertical.
- To avoid damage, use the opened out packaging to build the enclosure on.

EQUIPMENT NEEDED:

Drill, 6mm Masonry Bit, 3mm Metal Bit (general), Crosshead Screwdriver, Spirit Level, Pencil, Fine Tooth Saw, Silicone Sealant, Scissors, Tape Measure.

Note: The screws and wall plugs supplied are for masonry walls. For lightweight walls i.e. stud partitions, plasterboard etc, use the correct type of fixings.

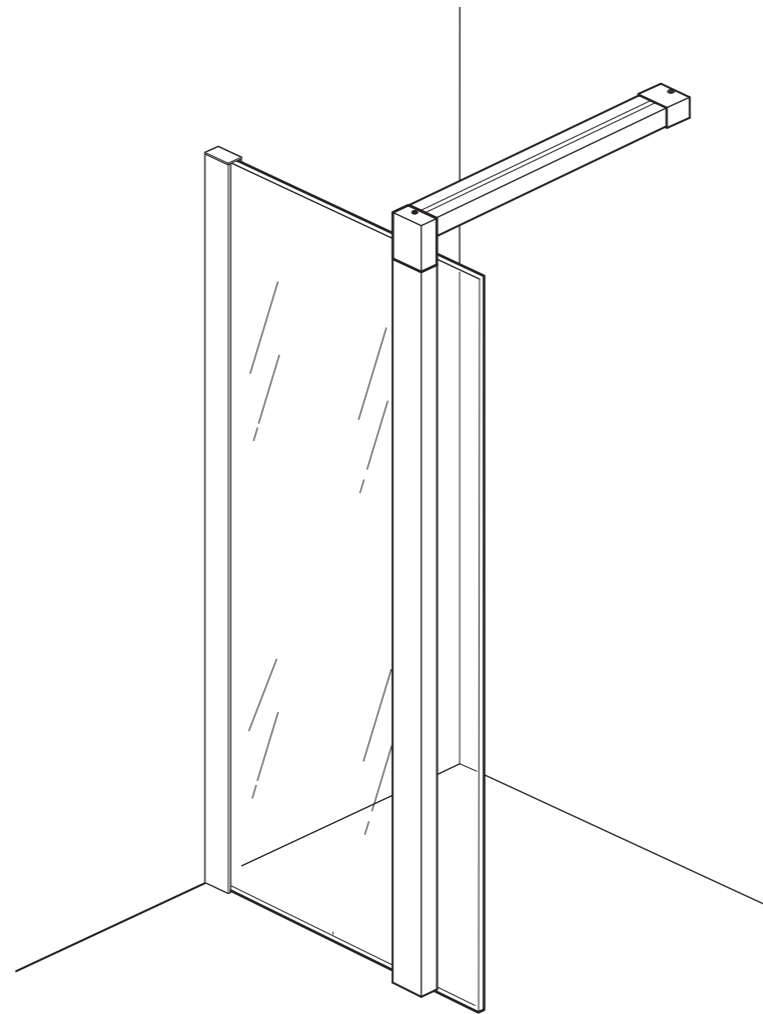



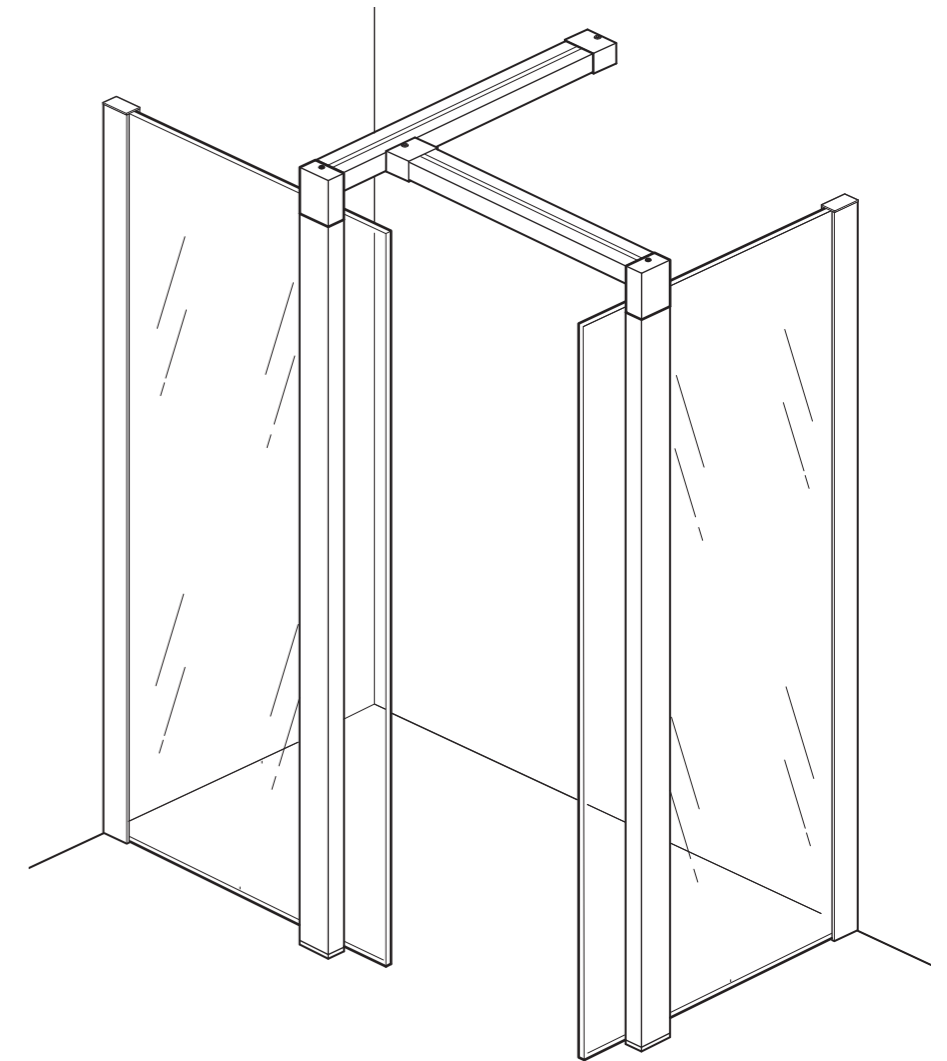





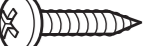

OPTION 1 - PAGES 2 - 3

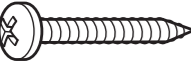
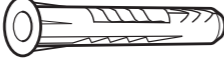
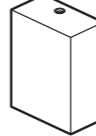

OPTION 2 - PAGES 4 - 6

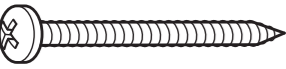
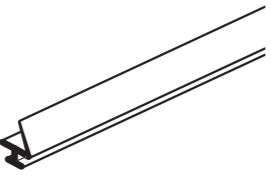
Check contents of the pack before installation. If there is anything missing, contact our Customer Care Number for assistance. **The fixings may be spread across several packs - please check the contents of each pack carefully.**

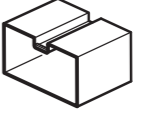
CUSTOMER CARELINE: 01746 713410

| OPTIONS: | | 1 | 2 | OPTIONS: | | 1 | 2 | OPTIONS: | | 1 | 2 | OPTIONS: | | 1 | 2 |
|---|-----------------------|---|----|---|----------------------|---|----|---|-------------------------------|---|---|---|--------------------------|---|---|
|  | PN9946 25mm Screw | 8 | 16 |  | PN60203 Washer | 6 | 11 |  | PN60276 Top column bracket | 1 | 2 |  | PN50232 Cover | 3 | 6 |
|  | PN60306 38mm Screw | 4 | 8 |  | PN60210 Wall plug | 6 | 10 |  | PN60277 Corner cover | 1 | 2 |  | PN60307 Grub screw | 2 | 4 |
|  | PN8211 50mm Screw | 2 | 3 |  | PN40063 Seal | 2 | 4 |  | PN60186 Column end | 1 | 2 |  | PN60275 Strut end | 1 | 2 |
| | | | | | | | | | | | |  | PN60274 Strut bracket | 1 | 2 |
| | | | | | | | | | | | |  | PN50247 Top cap | 1 | 2 |
| | | | | | | | | | | | |  | PN60162 3mm Allen key | 1 | 1 |

OPTION 1

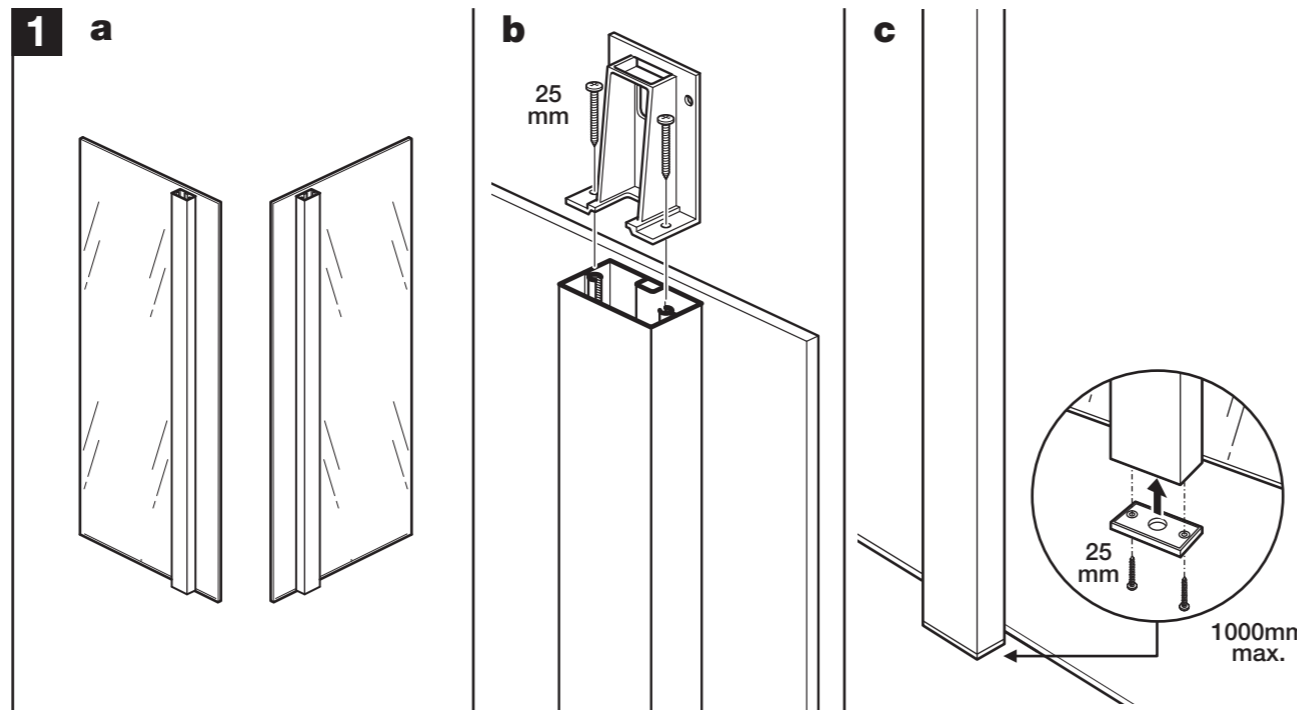
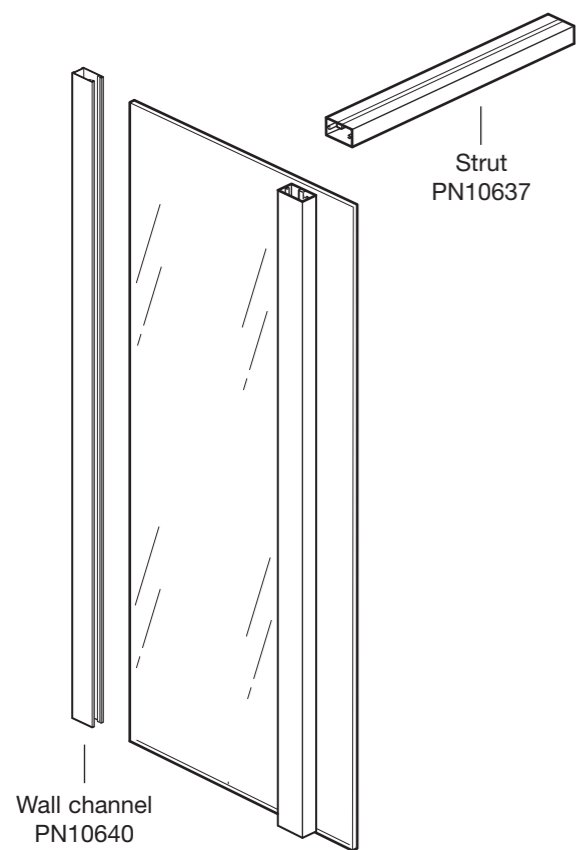

a: Choose either left or right opening, turn the panel over to suit.
b: Fit the top column bracket onto the top of panel column using 25mm screws.
c: Fit the column end onto the bottom of the panel column using 25mm screws.

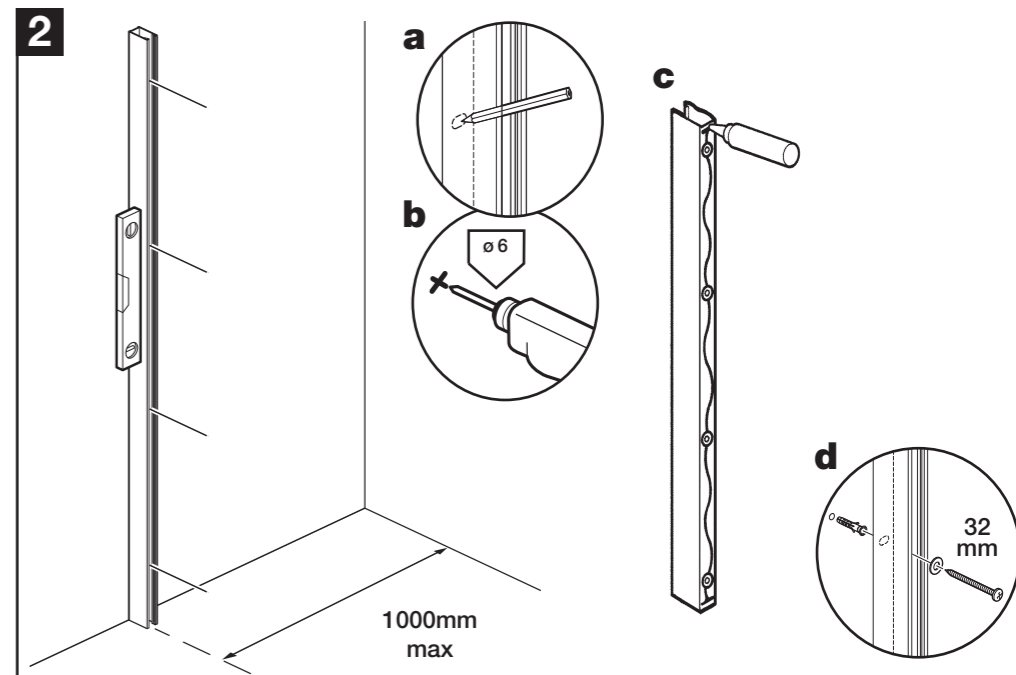

Place the wall channel in position against the wall at the required distance from the opposite wall, as shown (a maximum of 1000mm).
a: Ensure the wall channel is vertical and mark the four holes onto the wall.
b: Drill the four positions marked using a 6mm drill bit.
c: Apply silicone sealant to the back of the wall channel
d: Insert the wall plugs. Place washers over the 38mm screws and fix the wall channel to the wall. If necessary, slight adjustment is available in the wall channel.

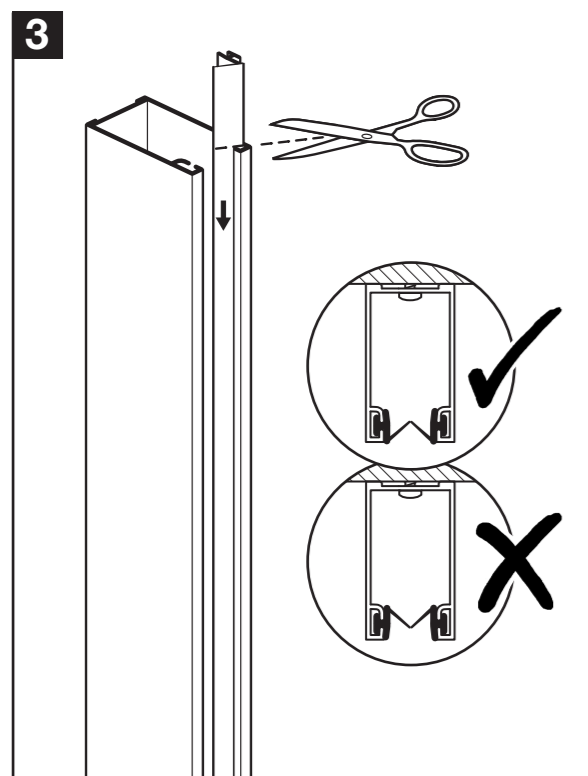

Slide both seals down into the wall channel and cut off any excess.
Note the orientation of the soft flippers.

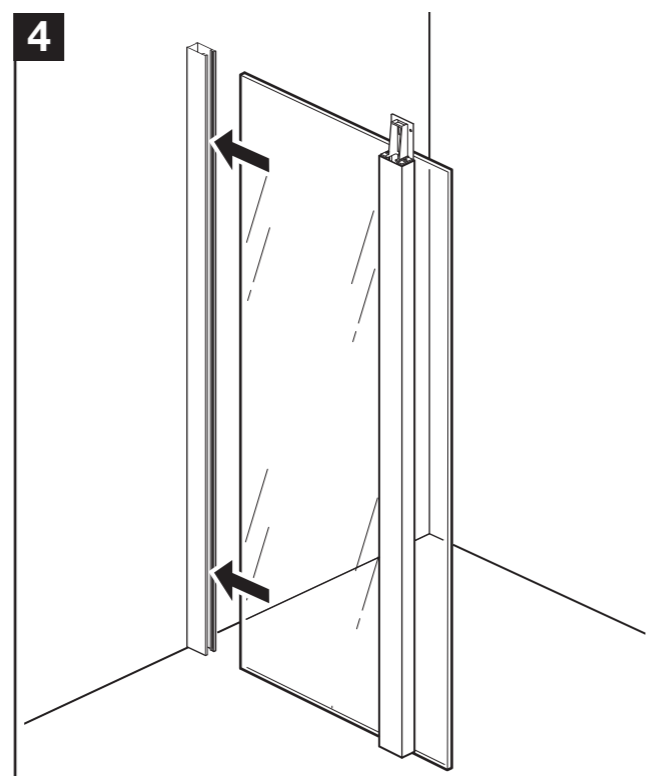

Carefully push the panel into the wall channel.
Note: Wetting the edge of the panel with water will help the panel insert.

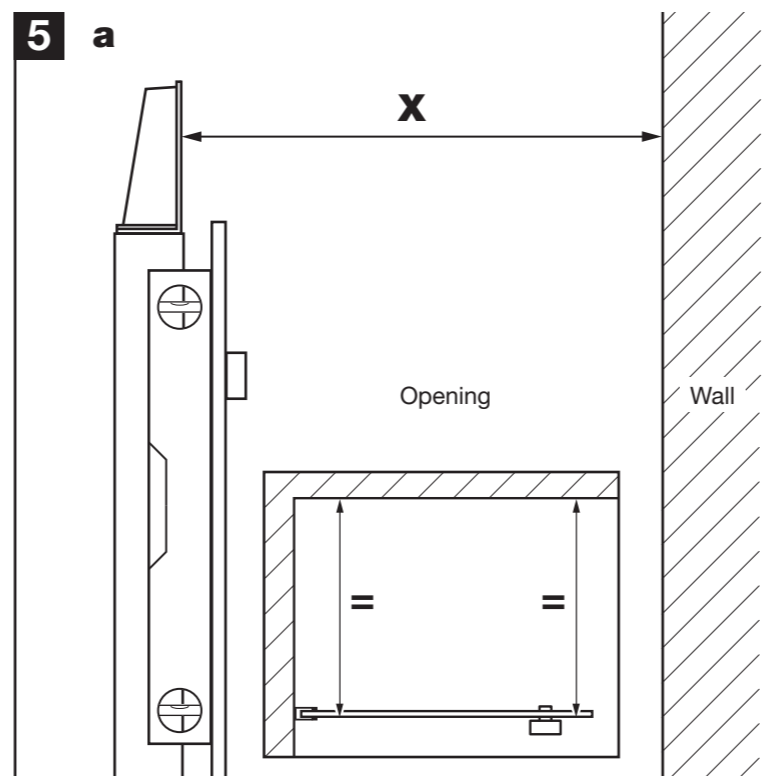

a: Ensure that the opening end of the panel is vertical and the panel is parallel with the opposite wall. Carefully measure the distance 'X' between the top column bracket and the wall.
b: Subtract 40mm from the opening distance 'X' and mark that measurement onto the horizontal strut. Using a fine tooth saw, cut the horizontal strut to size. Attach the strut end to the cut end of the strut using 2 x 25mm screws. Loosely insert the grub screw.

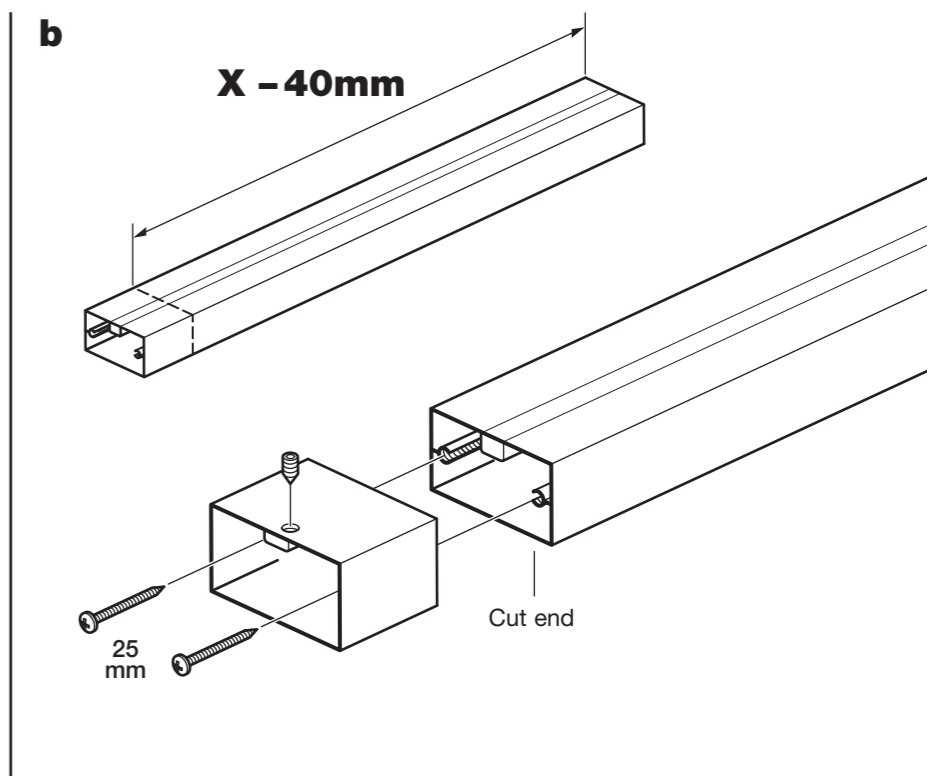

b: Subtract 40mm from the opening distance 'X' and mark that measurement onto the horizontal strut. Using a fine tooth saw, cut the horizontal strut to size. Attach the strut end to the cut end of the strut using 2 x 25mm screws. Loosely insert the grub screw.

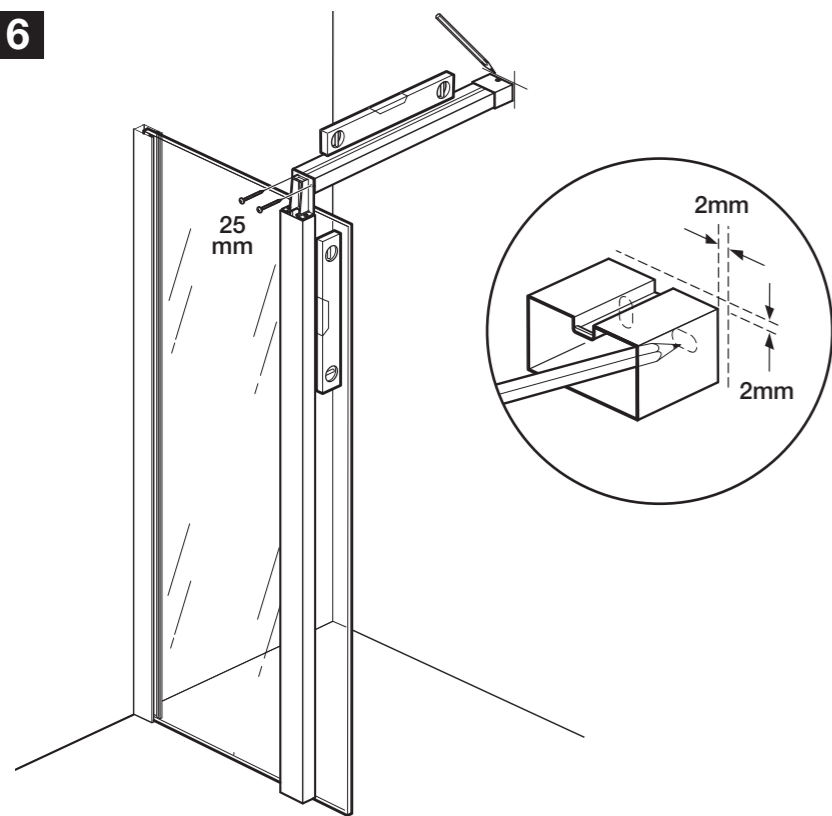
6

Fix the horizontal strut onto the top column bracket using 25mm screws. Ensure the horizontal strut is level and mark around the strut end. Remove the horizontal strut. Position the strut bracket onto the wall 2mm inside the marked lines and with the slot at the top. When correctly positioned, mark the fixing holes onto the wall.

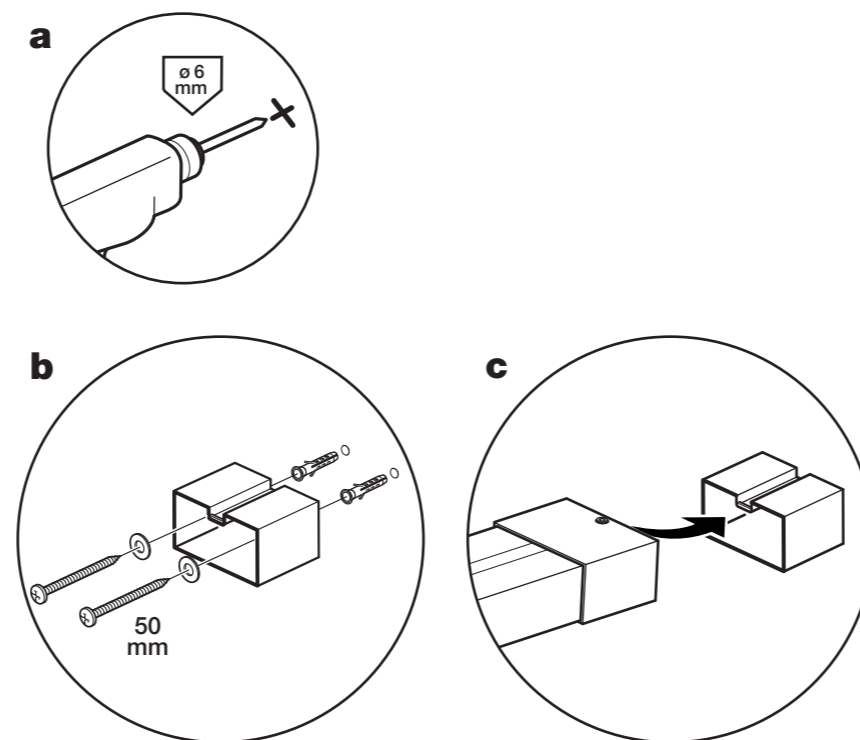
7

a: Drill the two positions marked using a 6mm drill bit.
b: Insert the wall plugs. Place washers over the 50mm screws and fix the strut bracket to the wall.
Note: The screws and wall plugs supplied are for masonry walls. For lightweight walls i.e. stud partitions, plasterboard etc, use the correct type of fixings.
c: Position the horizontal strut onto the strut bracket, at the same time fix the other end to the top column bracket using 25mm screws. Ensure the panel is vertical and tighten the grub screw onto the strut bracket using the 3mm Allen key.

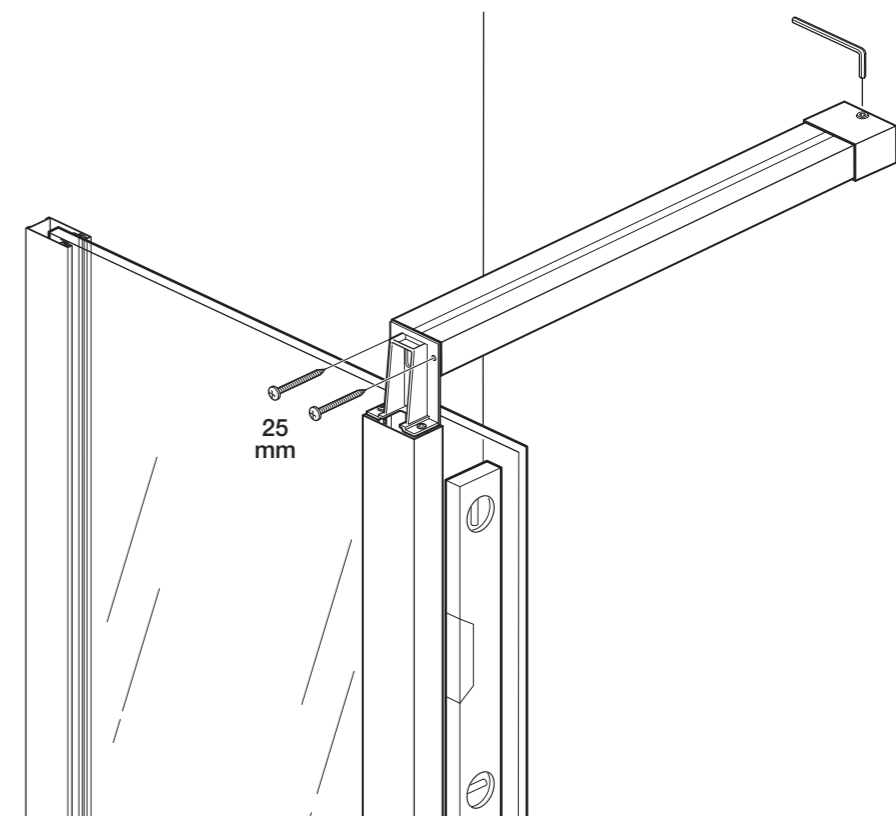
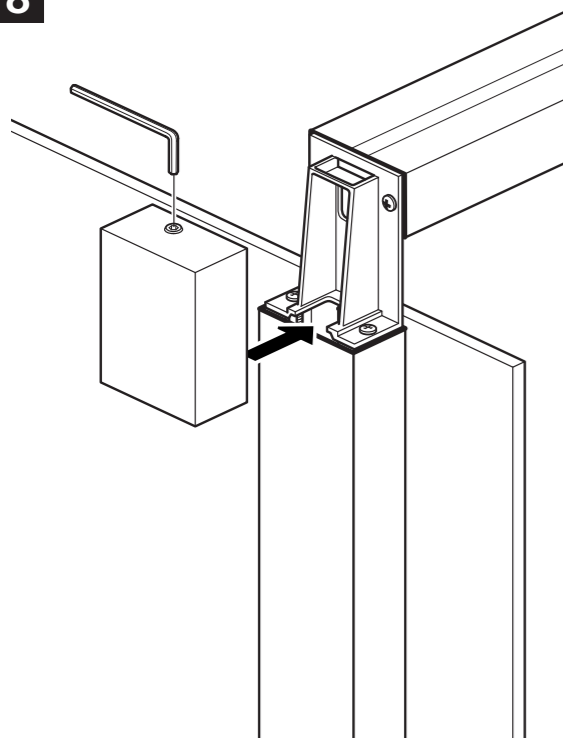
**8**

Insert the grub screw into the corner cover and position onto the top column bracket, tighten using the 3mm Allen key.

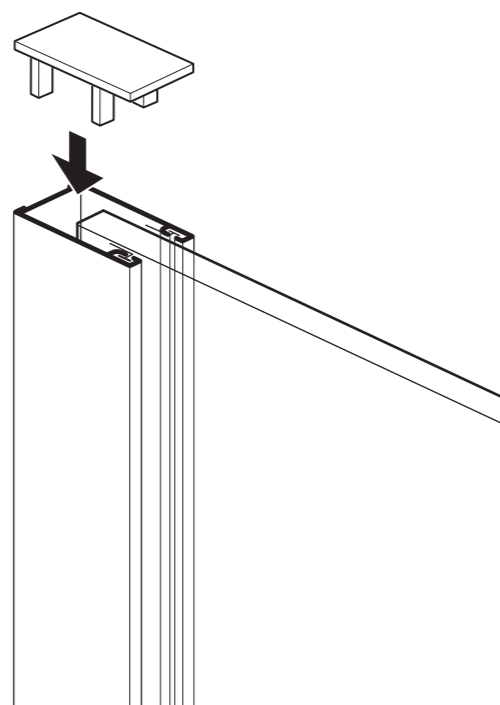
9

Push-fit the top cap onto the top of the wall channel.

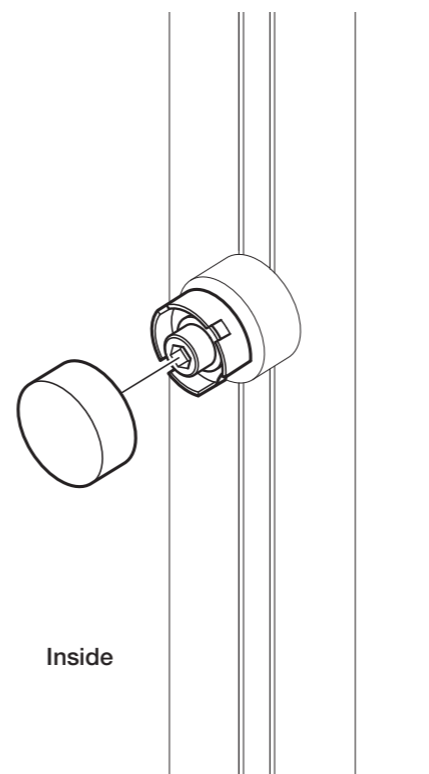
10

Push-fit the covers onto the screws on the inside of the panel columns.

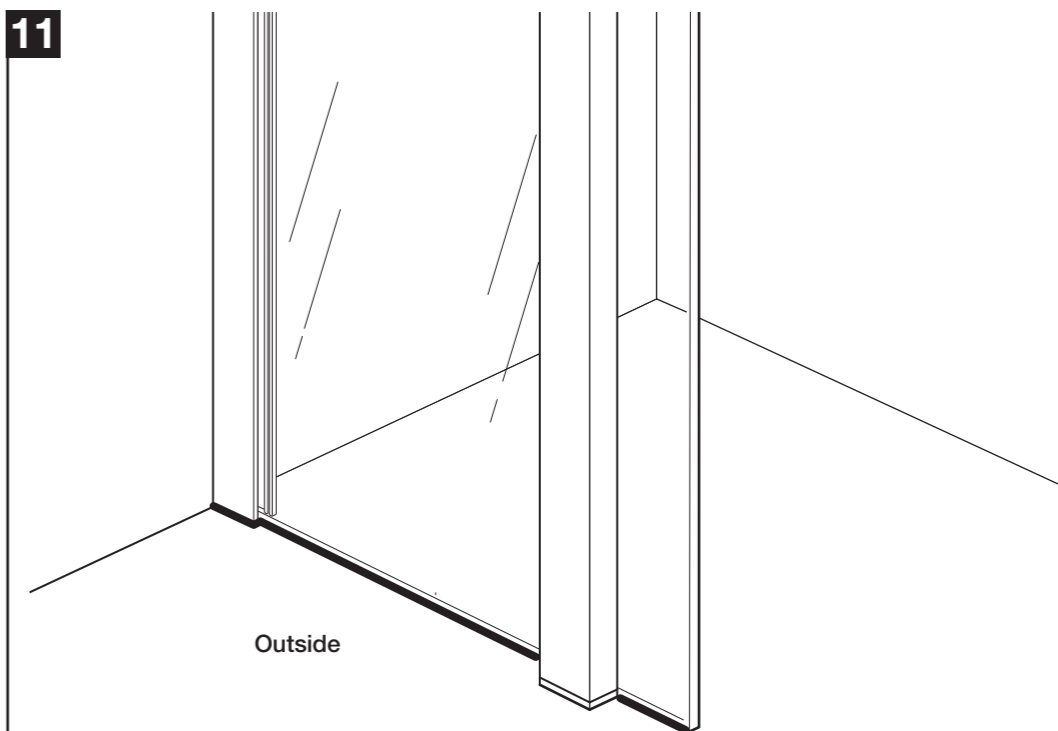
11

From outside only, From outside only, apply silicone sealant along the bottom of the panel as shown.

OPTION 2

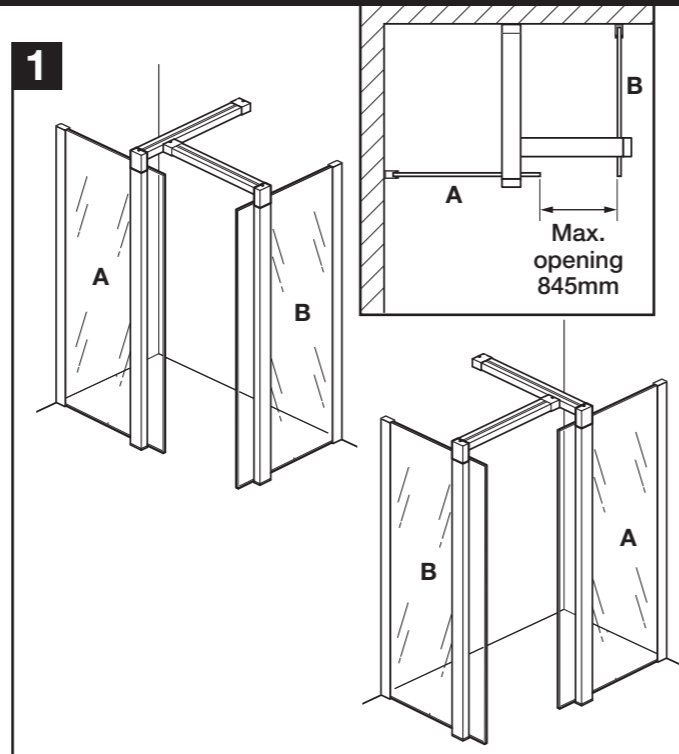
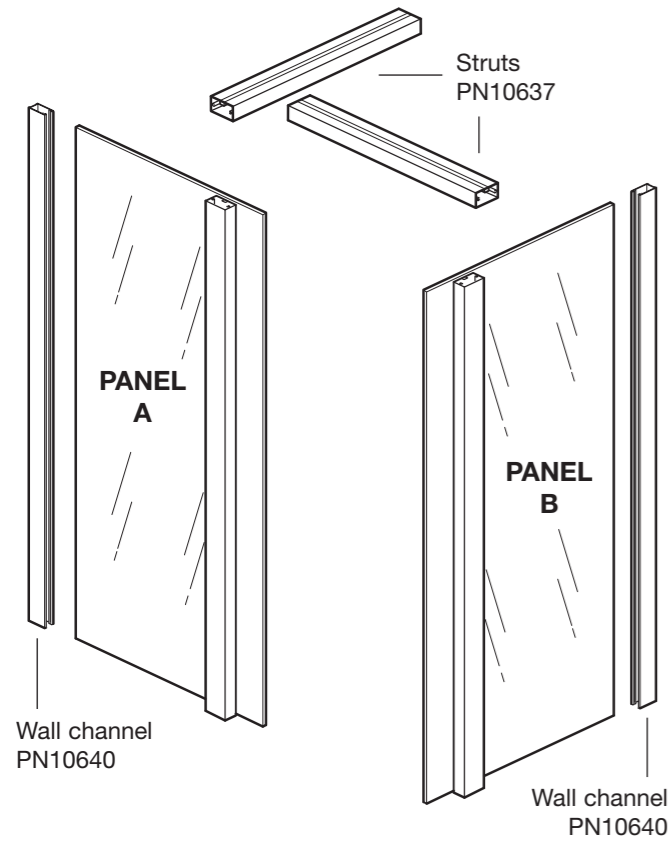

Choose either left or right opening, turn panels **A** and **B** over to suit.

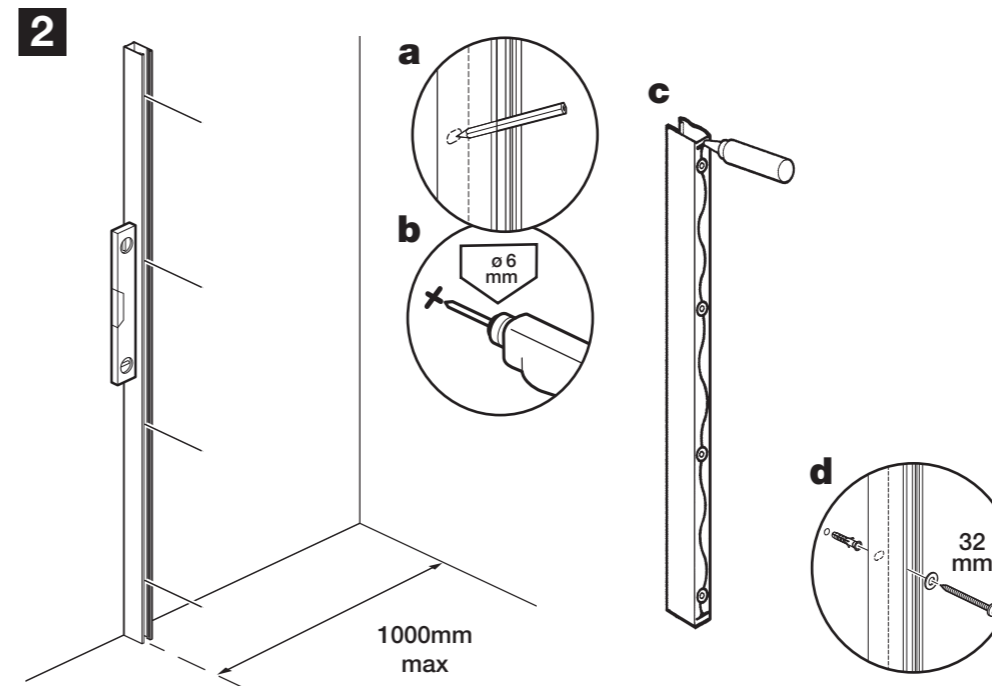

Plan the position for the panels. Place the first wall channel in position against the wall at the required distance from the opposite wall, as shown (a maximum of 1000mm).

- a:** Ensure the wall channel is vertical and mark the four holes onto the wall.
- b:** Drill the four positions marked using a 6mm drill bit
- c:** Apply silicone sealant to the back of the wall channels
- d:** Insert the wall plugs. Place washers over the 38mm screws and fix the wall channel to the wall. If necessary, slight adjustment is available in the wall channel.

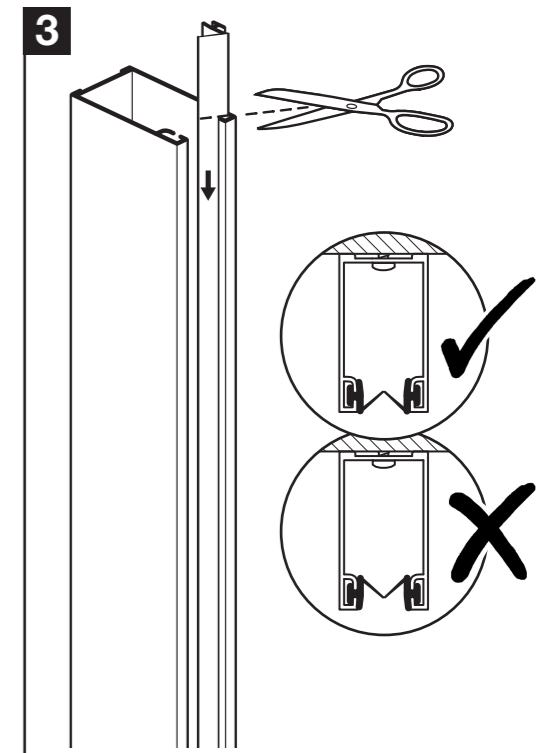

Slide both seals down into the wall channel and cut off any excess.

Note the orientation of the soft flippers.

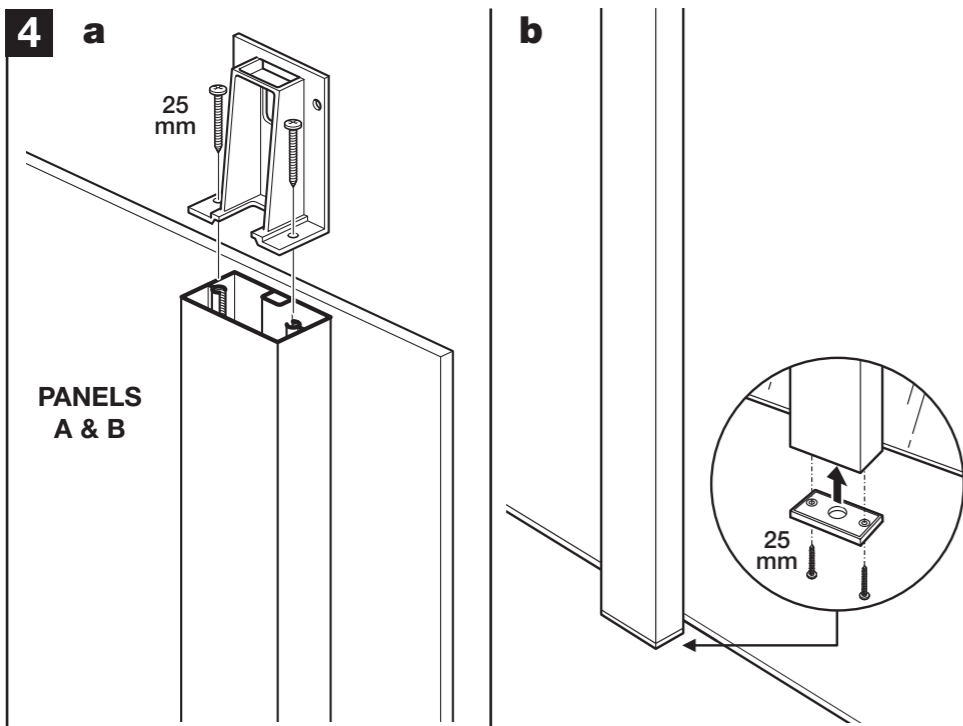

Select panels **A** & **B**.

- a:** Fit the top column brackets onto the top of panel columns using 25mm screws.
- b:** Fit the column ends onto the bottom of the panel columns using 25mm screws.

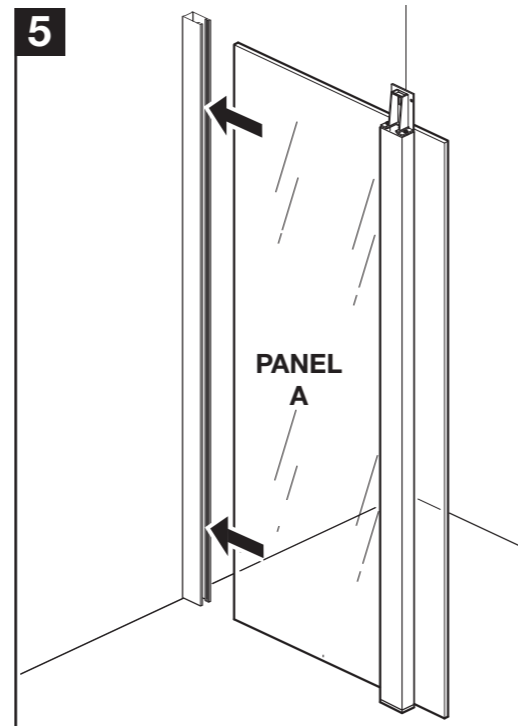

Carefully push panel **A** into the wall channel.

Note: Wetting the edge of the panel with water will help the panel insert.

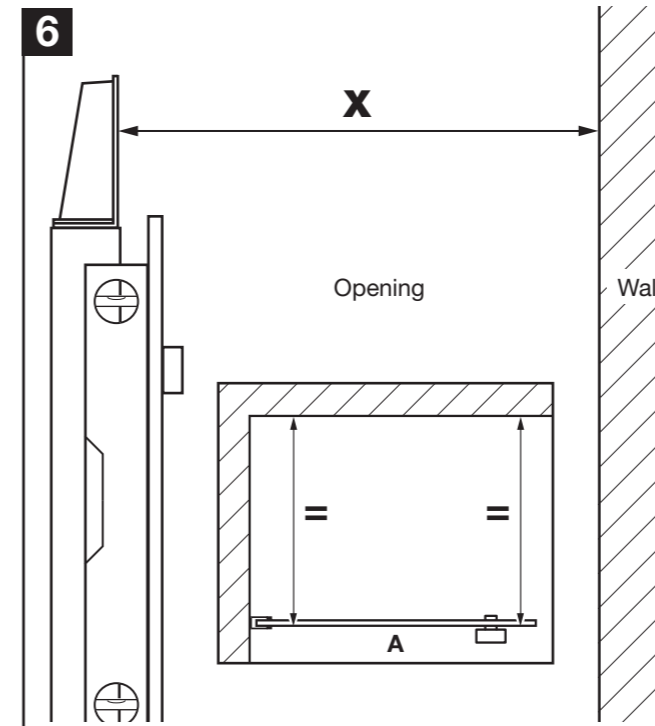

Ensure that the opening end of the panel is vertical and the panel is parallel with the opposite wall.

Carefully measure the distance '**X**' between the top column bracket and the wall.

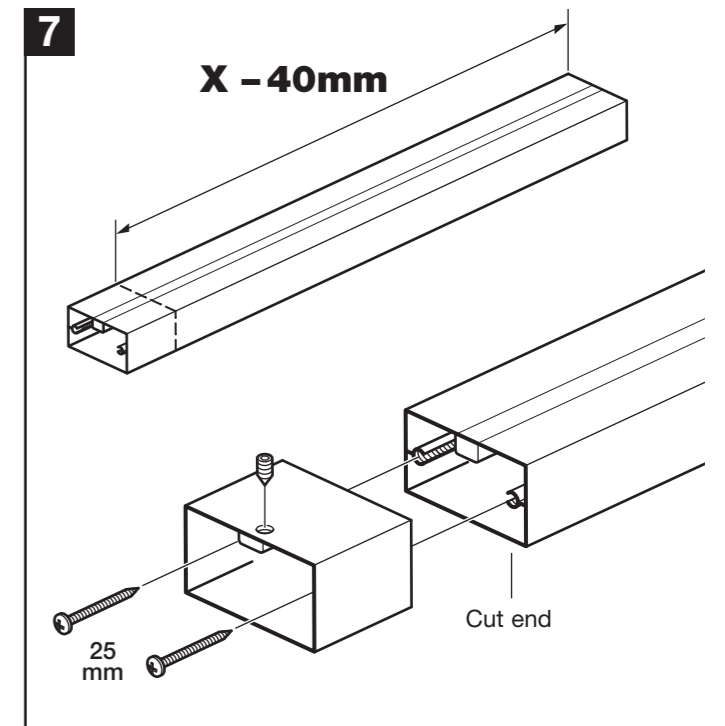

Subtract 40mm from the opening distance '**X**' and mark that measurement onto the horizontal strut.

Using a fine tooth saw, cut the horizontal strut to size. Attach the strut end to the cut end of the strut using 2 x 25mm screws. Loosely insert the grub screw.

8

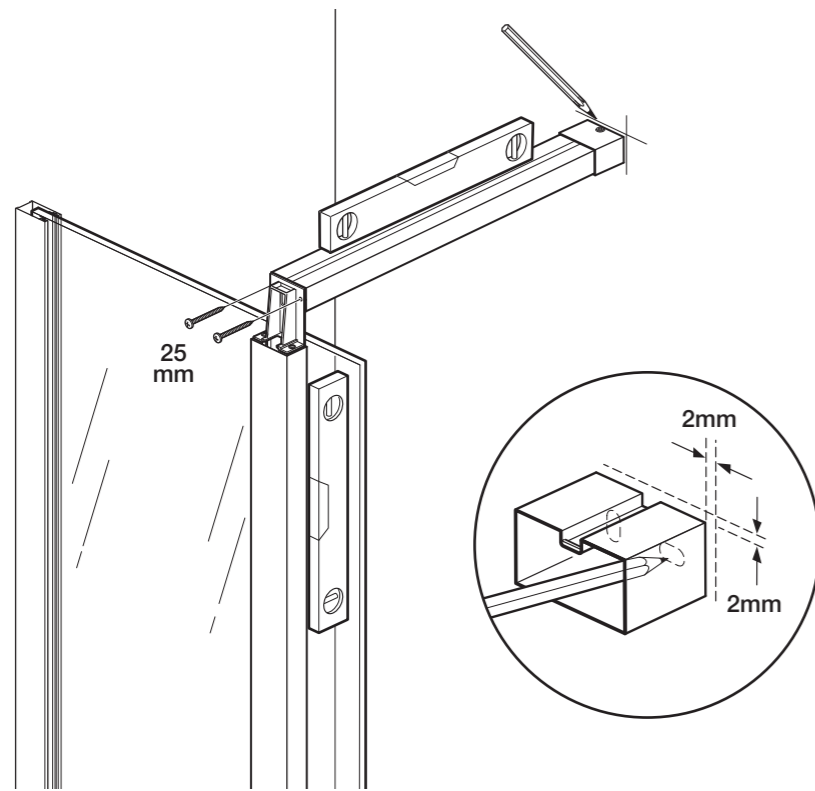

Fix the horizontal strut onto the top column bracket using 25mm screws. Ensure the horizontal strut is level and mark around the strut end. Remove the horizontal strut.

Position the strut bracket onto the wall 2mm inside the marked lines and with the slot at the top. When correctly positioned, mark the fixing holes onto the wall.

9

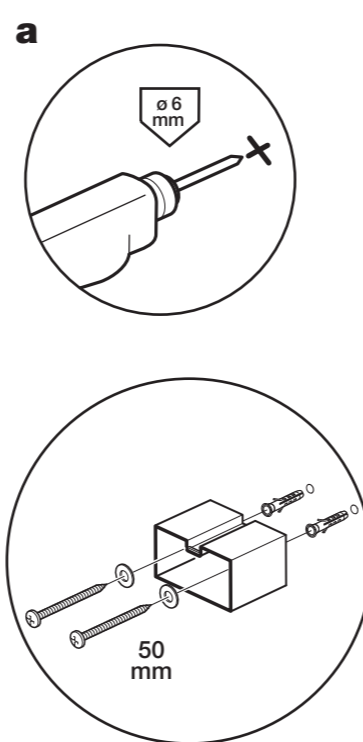

a: Drill the two hole positions marked using a 6mm drill bit. Insert the wall plugs. Place washers over the 50mm screws and fix the strut bracket to the wall.

Note: The screws and wall plugs supplied are for masonry walls. For lightweight walls i.e. stud partitions, plasterboard etc, use the correct type of fixings.

b: Position the horizontal strut onto the strut bracket, at the same time fix the other end to the top column bracket using 25mm screws. Ensure the panel is vertical and tighten the grub screw onto the strut bracket using the 3mm Allen key.

b

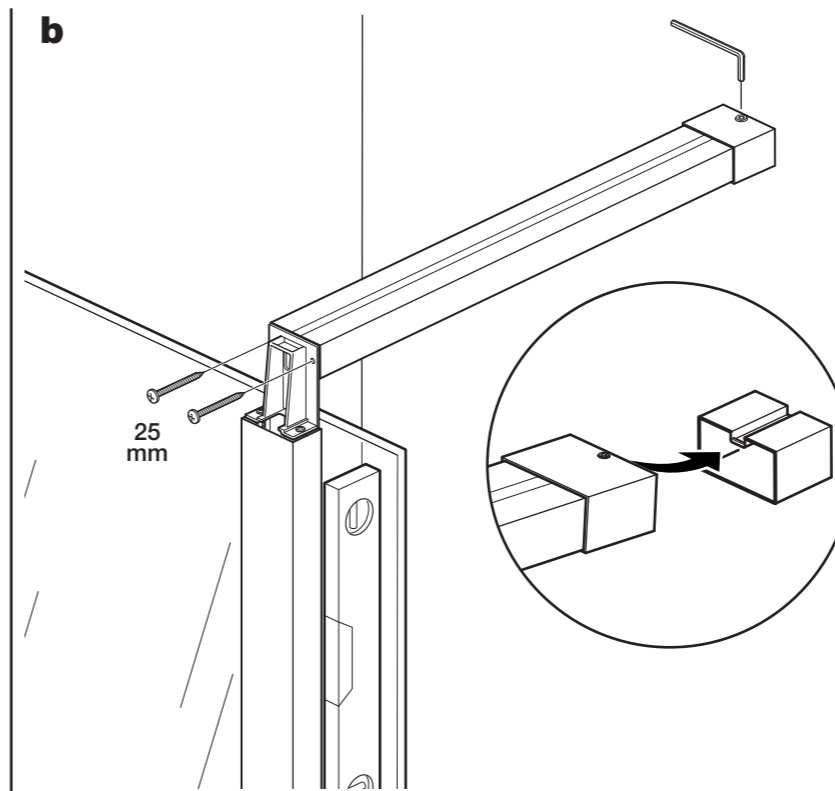

10

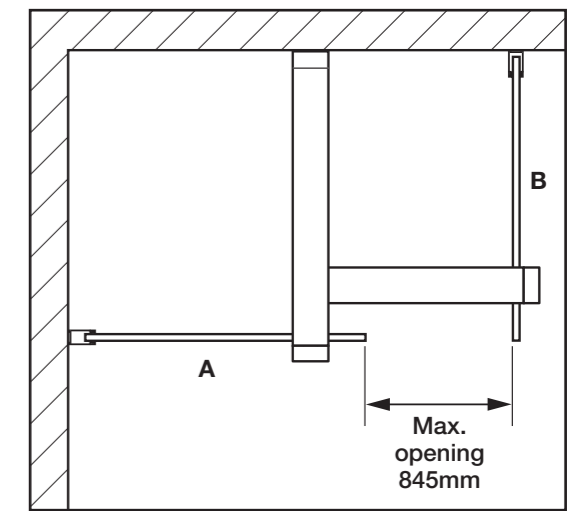

Plan the position for panel **B**, the opening can be a maximum of 845mm.

11

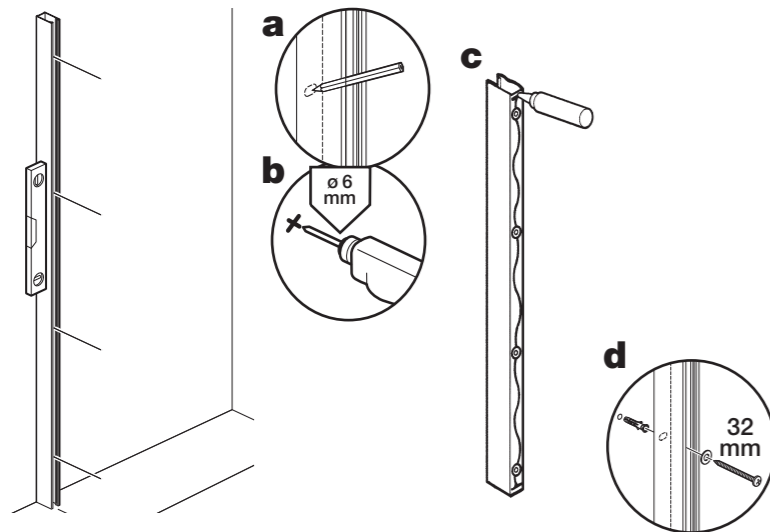

Place the wall channel in position against the wall.

a: Ensure the wall channel is vertical and mark the four holes onto the wall.

b: Drill the four positions marked using a 6mm drill bit.

c: Apply silicone sealant to the back of the wall channels

d: Insert the wall plugs. Place washers over the 38mm screws and fix the wall channel to the wall. If necessary, slight adjustment is available in the wall channel.

12

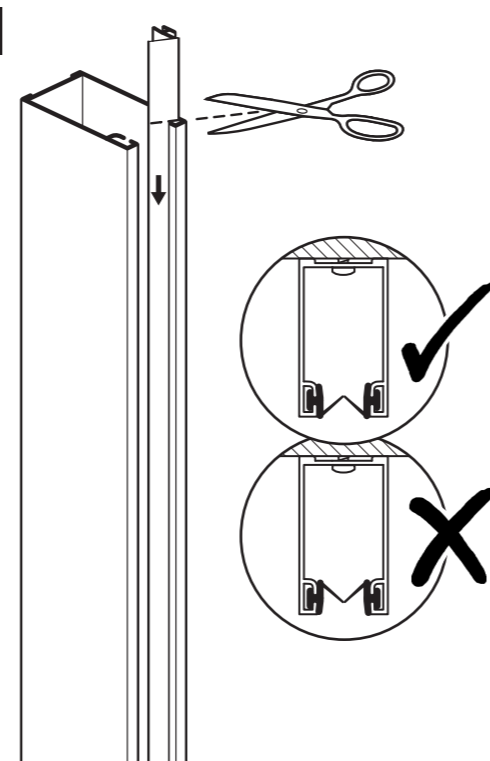

Slide both seals down into the wall channel and cut off any excess.

Note the orientation of the soft flippers.

13

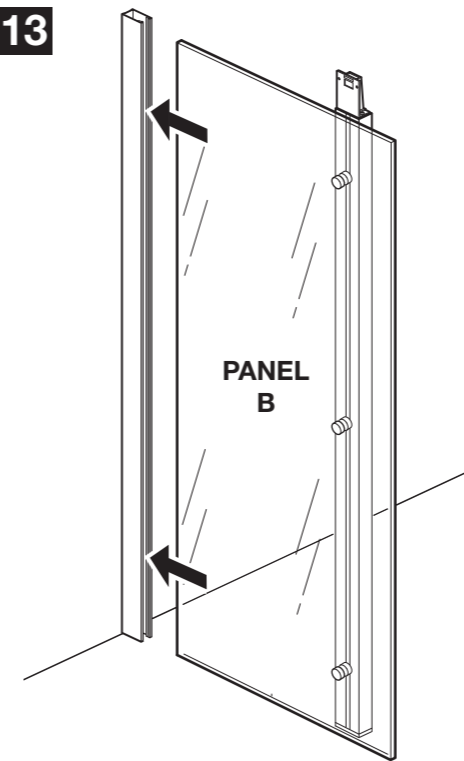

Carefully push panel **B** into the wall channel.

Note: Wetting the edge of the panel with water will help the panel insert.

14

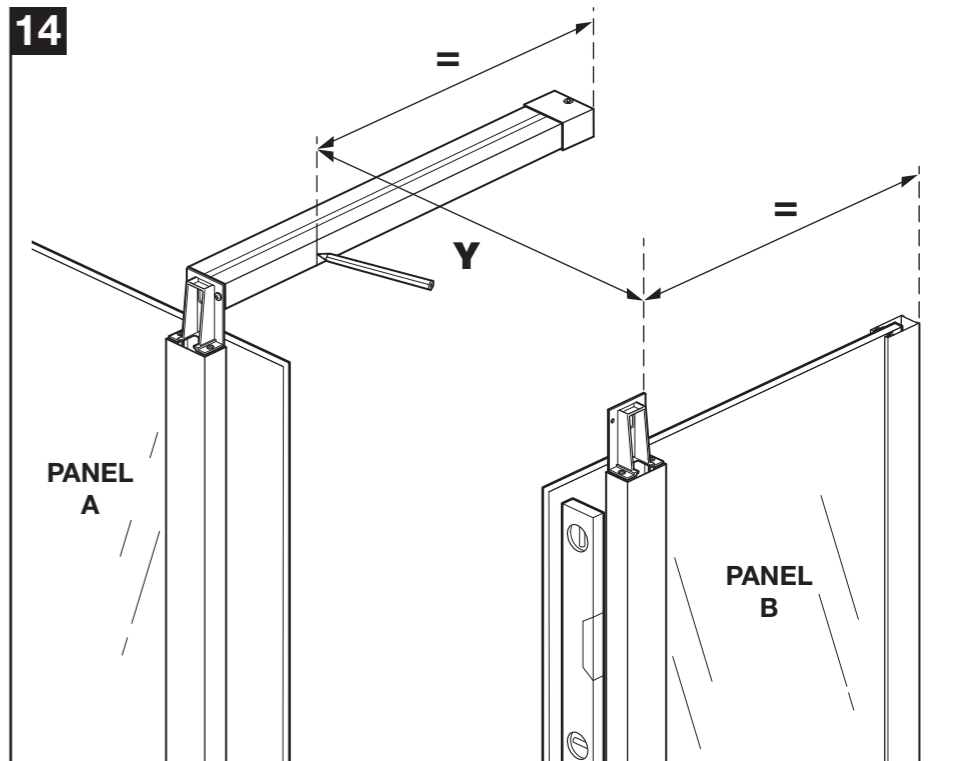

Ensure that the end of panel **B** is vertical.

Measure the distance between the top column bracket and the fitted strut (as shown) and mark this same distance onto the fitted horizontal strut. This gives the position for the next strut bracket.

Carefully measure the distance '**Y**' between the top column bracket and the fitted horizontal strut.

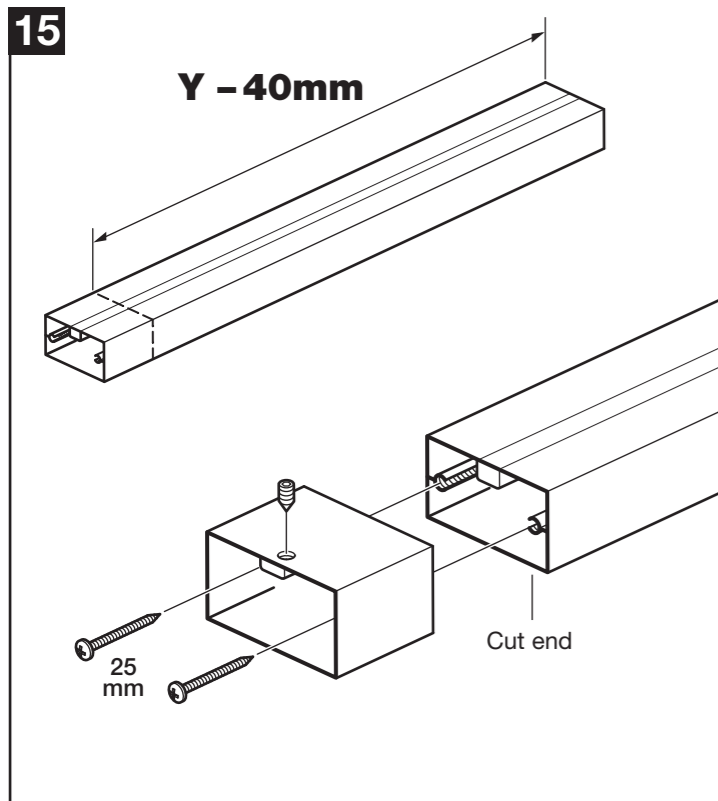

Subtract 40mm from the opening distance 'Y' and mark that measurement onto the horizontal strut.
Using a fine tooth saw, cut the horizontal strut to size.
Attach the strut end to the cut end of the strut using 2 x 25mm screws. Loosely insert the grub screw.

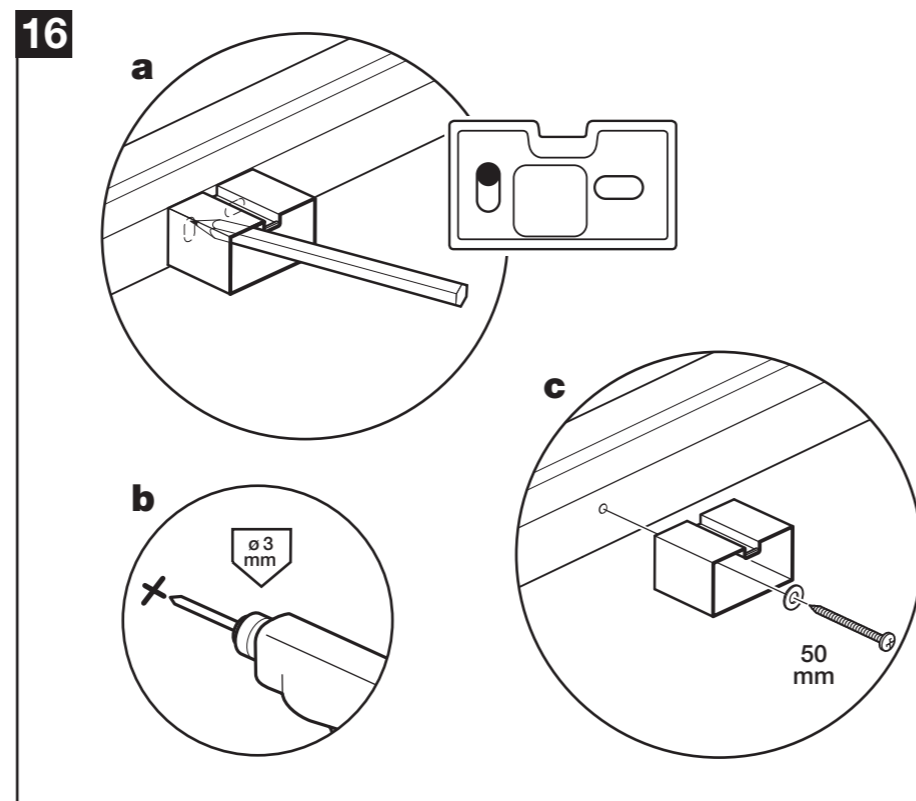

a: Position the strut bracket onto the fitted horizontal strut, line up and **ONLY** mark the vertical fixing slot onto the strut. **Note:** Mark the hole at the top of the slot as shown to make it easier to drill into the strut.
b: Drill the hole marked using a 3mm drill bit.
c: Place a washer over the 50mm screw and fix the strut bracket to the fitted strut.

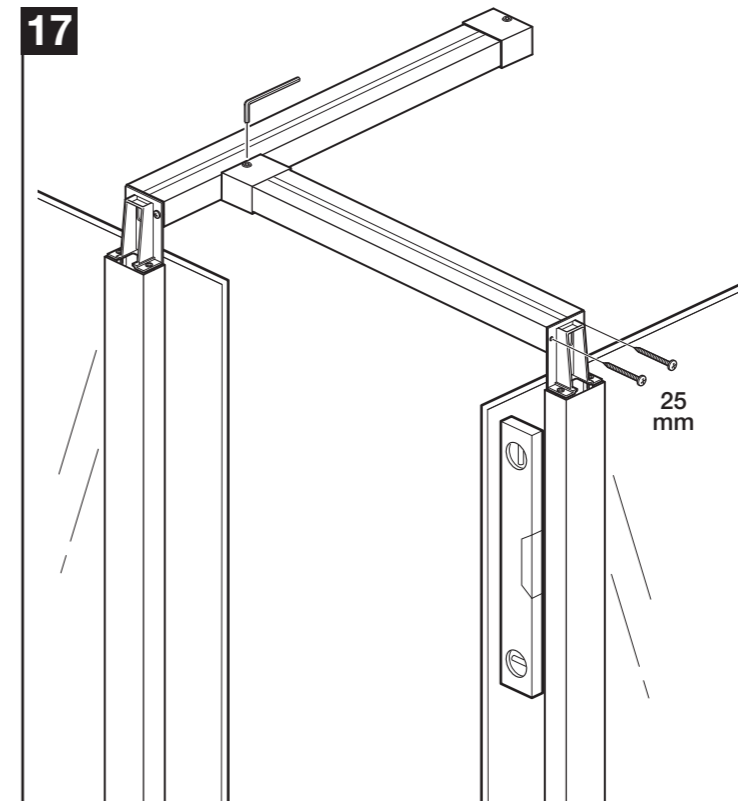

Position the horizontal strut onto the strut bracket, at the same time fix the other end to the top column bracket using 25mm screws.
Ensure the panel is vertical and tighten the grub screw onto the strut bracket using the 3mm Allen key.

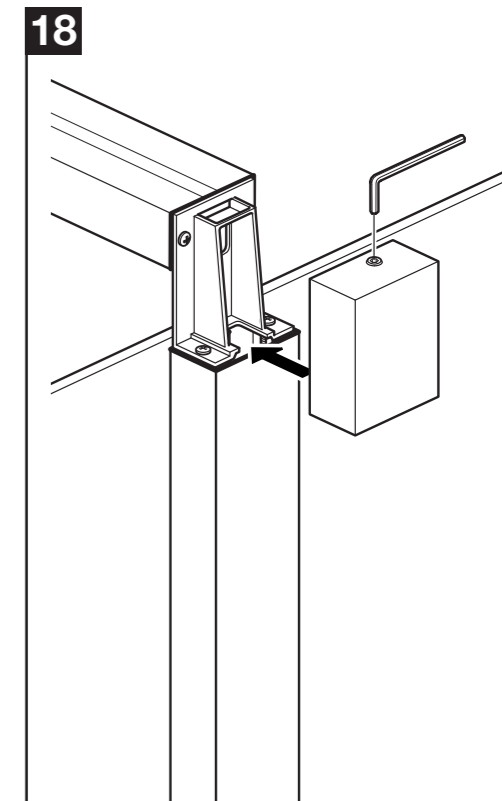

Insert the grub screws into the corner covers and position onto the top column brackets, tighten using the 3mm Allen key.

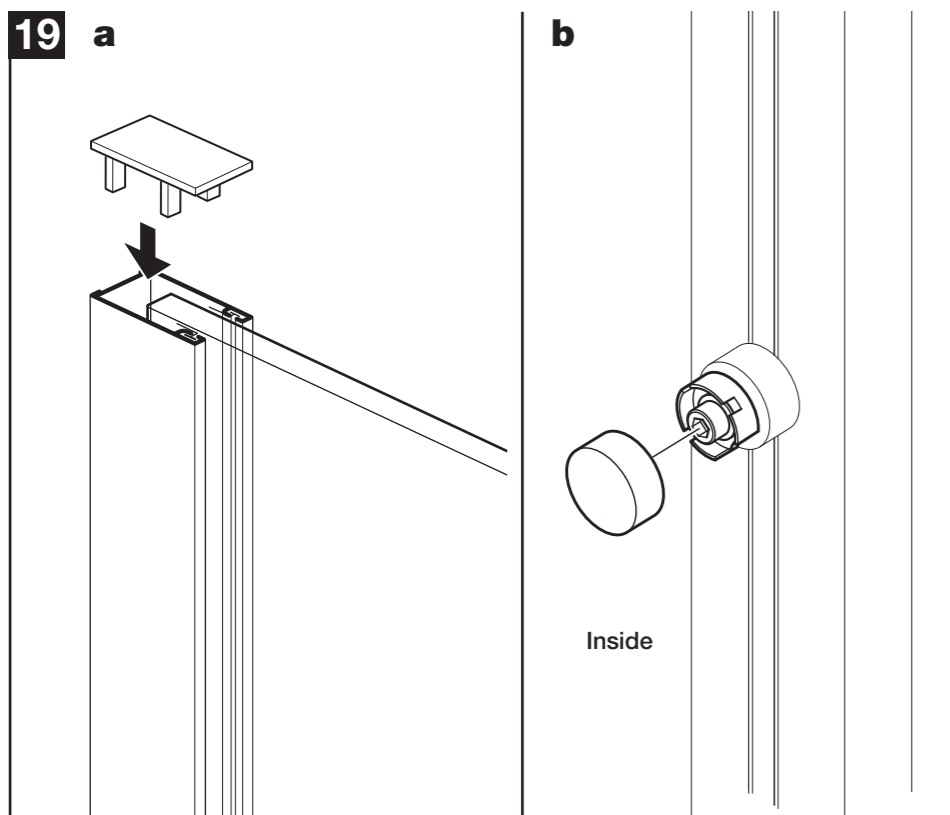

a: Push-fit the top caps onto the wall channels.
b: Push-fit the covers onto the screws on the inside of the panel columns.

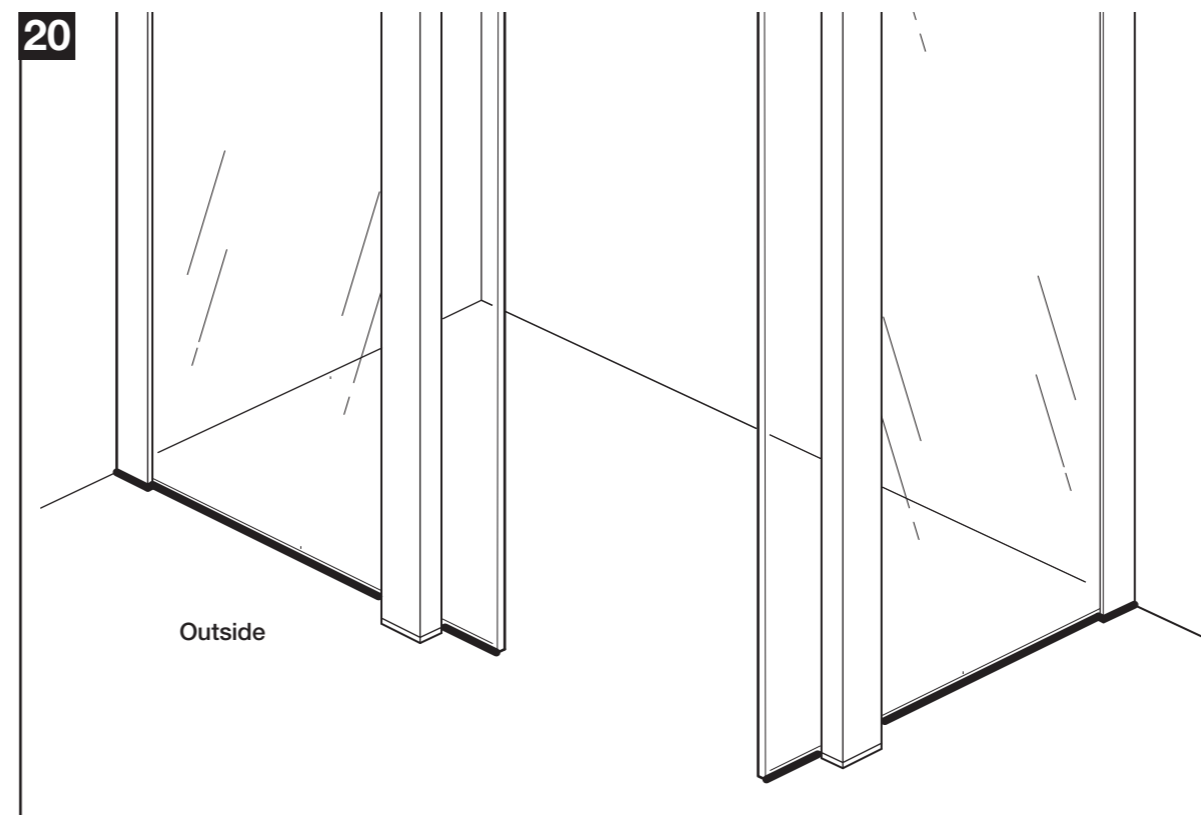

From outside only, apply silicone sealant along the bottom of the panels as shown.

! CARE AND MAINTENANCE
IMPORTANT: When silicone sealant is used you must not use or work on the enclosure for 24 hours after installation.
DO NOT use bleach, scouring powders, solvents or other aggressive cleaning agents. To clean use warm soapy water and a clean cloth and rinse off.
Periodically check all fixings and tighten if necessary.

**A PRODUCT OF
THE CORAM GROUP
OF COMPANIES**
Coram Showers Limited
Stanmore Industrial Estate
Bridgnorth
Shropshire WV15 5HP, UK
www.coram.co.uk

**CUSTOMER CARELINE:
01746 713410**