

Attach the baskets to the front and rear clamp brackets using the 25mm screws (clamping basket strut in between). Tighten using a screw driver, do not over tighten. Fit the front bracket covers over the front brackets. Push fit the ends caps.

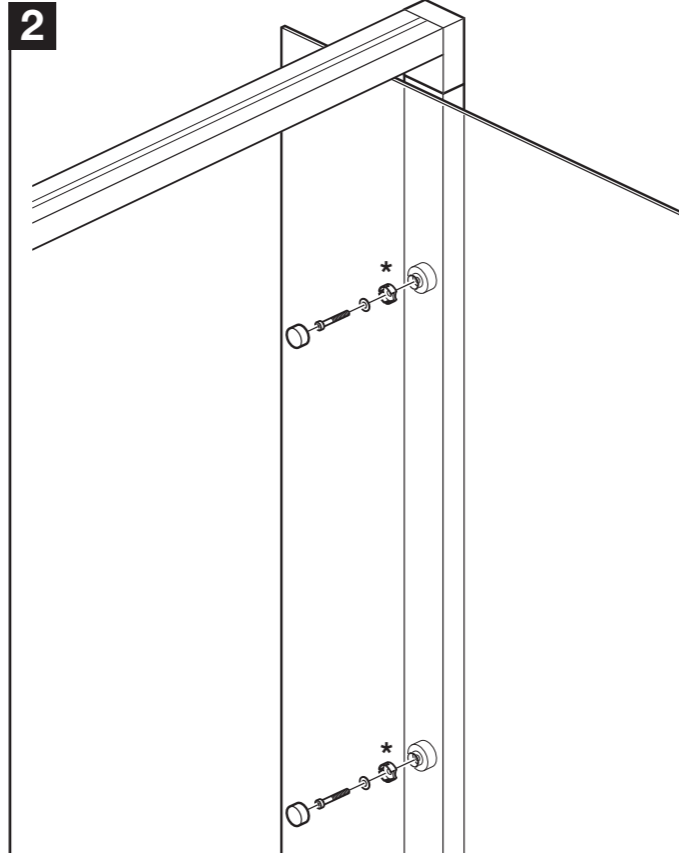

Remove the bolt caps, 30mm allen bolts, washers and inner glass bushes\* from the 'top two holes' on the inside of the panel. Use the 5mm allen key supplied.

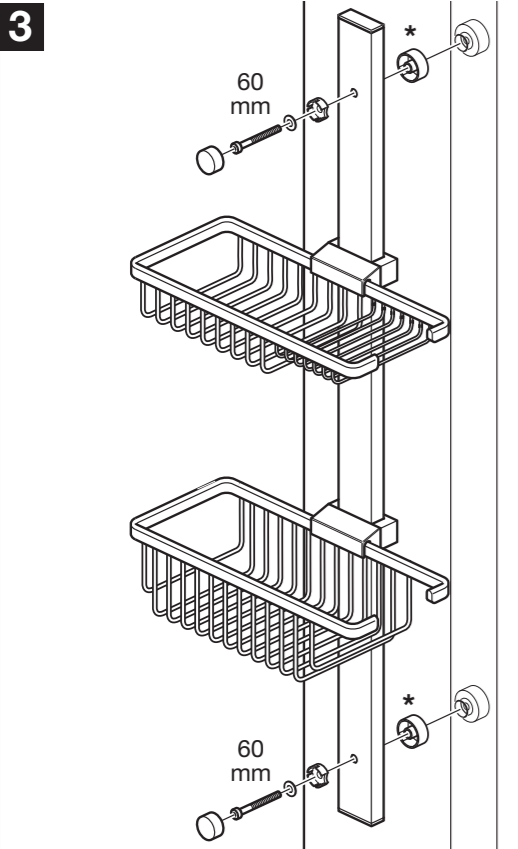

Attach the whole assembly to the panel, replacing the 30mm allen bolts with 60mm allen bolts. Ensure the glass bushes\* are positioned between the basket strut and glass. Replace the bolt caps.



**CARE AND MAINTENANCE**

**DO NOT** use bleach, scouring powders, solvents or other aggressive cleaning agents. To clean use warm soapy water and a clean cloth and rinse off.

**DO NOT** apply weight or pressure to the accessories.

Periodically check all fixings and tighten if necessary.

**A PRODUCT OF THE CORAM GROUP OF COMPANIES**

Coram Showers Ltd. Stanmore Industrial Estate, Bridgnorth, Shropshire WV15 5HP, UK  
Tel: 01746 766466 • Fax: 01746 764140  
www.coram.co.uk

**CUSTOMER CARELINE: 01746 713410**

**PILLAR SHOWER PANELS ACCESSORIES PACK**



Please read these instructions carefully and keep for future reference.

Incorrect fitting will invalidate the guarantee.

**SAFETY**

Handle glass with care. Sharp impacts can damage the metal components and could shatter the glass.

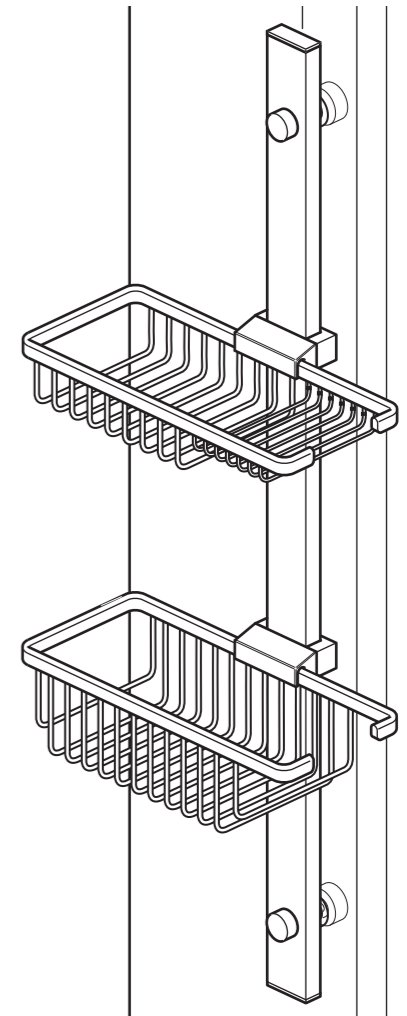

Only for use with Coram 'Pillar Shower Panels'.

The accessories can be attached to the panel during or after the installation of the panel.

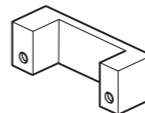
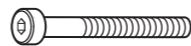
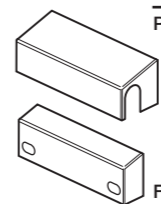

Check contents of pack before installation. If there is anything missing, contact our Customer Careline for assistance.

**CUSTOMER CARELINE: 01746 713410**

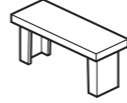
PN60325 	4	PN60326 	2
25mm Screw PN60198 	2	PN697 	2/2
60mm Allen bolt PN50230 	2	PN60211 	1
Glass bush PN60206 	2		

